



Plastische Chirurgie
Plastic Surgery
Cirugía Plástica
Chirurgia Plastica





Maltepe Mah.Eski ırpıcıyolu Sk.
Merter İş Merkezi D Blok 2/21
034234- Zeytinburnu, İstanbul

+90 212 482 71 52
info@redamed.com

Charrière (Ch) French (F)	Durchmesser in mm	Inches
1	0,33	0,013
2	0,67	0,025
3	1,00	0,039
4	1,33	0,051
5	1,67	0,065
6	2,00	0,0787
7	2,33	0,092
8	2,67	0,105
9	3,00	0,1181
10	3,33	0,131
11	3,67	0,144
12	4,00	0,1575
13	4,33	0,170
14	4,67	0,184
15	5,00	0,1968
16	5,33	0,210
17	5,67	0,223
18	6,00	0,2362
19	6,33	0,249
20	6,67	0,263
21	7,00	0,2756
22	7,33	0,288
23	7,67	0,302
24	8,00	0,3150
25	8,33	0,328
26	8,67	0,341
27	9,00	0,3543
28	9,33	0,367
29	9,67	0,380
30	10,00	0,3973
31	10,33	0,407
32	10,67	0,420
34	11,33	0,446
36	12,00	0,4724
38	12,67	0,494
40	13,33	0,5199
45	15,00	0,5905

Gauge (G)	Durchmesser in mm	Inches
35	0,13	0,005
34	0,18	0,007
33	0,20	0,008
32	0,23	0,009
31	0,25	0,010
30	0,30	0,012
29	0,33	0,013
28	0,36	0,014
27	0,41	0,016
26	0,46	0,018
25	0,51	0,020
	0,53	0,021
24	0,56	0,022
23	0,64	0,025
22	0,71	0,028
21	0,81	0,032
20	0,89	0,035
	0,97	0,038
19	1,07	0,042
18	1,27	0,050
17	1,50	0,059
16	1,65	0,065
15	1,83	0,072
14	2,11	0,083
13	2,41	0,095
12	2,77	0,109
11	3,05	0,120
10	3,40	0,134
9	3,76	0,148
8	4,19	0,165
7	4,57	0,180
6	5,16	0,203

1 OZ	0,028 ml
5 OZ	0,140 ml
16 OZ	0,450 ml

35 OZ	1,0 l
128 OZ	3,7 l

GARANTIE / WARRANTY / GARANTIA / GARANZIA

GARANTIE

Wir gewähren auf alle **Reda**-Instrumente 5 Jahre Garantie. Voraussetzung ist der sach- und fachgerechte Einsatz der Instrumente. Von der Garantie sind Verschleißerscheinungen ausgeschlossen.

WARRANTY

Our **Reda** products are free from manufacturing defects in material and workmanship. We therefore give on all instruments a guarantee of five years provided that the instruments are maintained and cleaned properly and used normally for their intended purpose.

GARANTIA

Estamos convencidos de nuestra calidad y concedemos a todos los instrumentos de **Reda** 5 años de garantía contra cualquier defecto de fabricación, siempre y cuando se usen adecuadamente. De la garantía excluimos la manifestación de desgaste.

GARANZIA

Siamo convinti della nostra qualità e concediamo cinque anni di garanzia sulla funzione dei tutti gli strumenti **Reda** sotto la presupposizione che l'utilizzo è da esperto. Escluso della garanzia sono tracce di consumo.

Indikationen und Kontraindikationen finden Sie in der entsprechenden Gebrauchsanweisung!

Indication and Contraindication please refer to our user`s manual!

Indicaciones y Contraindicaciones se encuentran en la instrucciones de uso correspondientes!

Indicazioni e contraindicazioni sono segnalti nel foglio istruzioni d'impiego.

Arbeitsanweisung **Aufbereitung (Reinigung) und Sterilisation von resterilisierbaren** **chirurgischen Instrumenten**

DIN EN ISO 17664:2004 (D)

Hersteller:
REDA Instrumente GmbH, Gänsäcker 34
78532 Tuttlingen

Alle von Reda gelieferten wieder verwendbaren Instrumente wurden ausschließlich für den chirurgischen Gebrauch konstruiert und dürfen zu keinen anderen Zwecken benutzt werden. Unsachgemäße Handhabung und sorglose Pflege sowie zweckentfremdeter Gebrauch können zu vorzeitigem Verschleiß der Instrumente führen. Die Produkte sind bei der Auslieferung nicht sterilisiert.

Reinigungsvorbereitung

Fabrikneue Instrumente müssen vor der ersten Anwendung den gesamten Aufbereitungsprozess durchlaufen. Instrumente unmittelbar nach Anlieferung aus den Folienverpackungen entnehmen und in trockenen Räumen bei gleichbleibender Raumtemperatur luftoffen lagern, um Kondensationsbildung zu vermeiden.

Die Instrumente keinen Sonnenlichteinstrahlungen oder Dämpfen durch Chemikalien (Säuren oder scharfe Reinigern) aussetzen.

Vor der ersten Sterilisation alle Schutzkappen und Folien vollständig entfernen und anschließend reinigen.

Gebrauchte Instrumente unmittelbar nach Beendigung des Eingriffs von Blut, Gewebe und Arzneimittel reinigen. Instrumente in eine freigegebene Lösung eines kombinierten Reinigungs- und Desinfektionsmittels, das keine proteinfixierende Wirkung besitzt, einlegen.

Dosierung des Herstellers beachten. Nicht in NaCl Lösung einlegen, ansonsten Gefahr für Loch- bzw. Spannungsriss-Korrosion

Überfüllung von Instrumentensieben und Wasch-Trays vermeiden.

Gelenkinstrumente vor dem Aufbereiten öffnen. Zerlegbare Instrumente gemäß Bedienungsanleitung (Piktogramm) zur Reinigung zerlegen. Reinigungsgerechtes Zubehör verwenden. Für die manuelle Reinigung nie Metallbürsten oder Metallschwämme verwenden.

Spülmaschinen und Ultraschallanlagen nicht überladen. Spül- oder Schallschatten vermeiden. Dosierung, Einwirkzeit und Einwirktemperatur bei der Desinfektion und Reinigung unbedingt einhalten. Nach der Reinigung sorgfältig spülen. Möglichst vollentsalztes (demineralisiertes) Wasser verwenden.

Nach dem Spülen ausreichend trocknen.

Abgenutzte, korrodierte, deformierte, poröse oder anderweitig beschädigte Instrumente aussortieren.

Aus hygienischen Gründen müssen Instrumente, die zur Reparatur eingesandt werden komplett aufbereitet werden.

Gelenkinstrumente nach jeder Aufbereitung mit einem Pflegemittel auf Basis von Paraffinöl behandeln (gilt nicht für flexible Endoskope und Zubehör).

Funktionsprüfung in zusammengebautem Zustand durchführen.

Instrumente mit Rastensperre vor der Sterilisation nur im ersten Zahn schließen.

Als Sterilisationsverfahren empfehlen wir die Dampfsterilisation (üblicherweise mit Sattedampf bei 134° C)

Sterilisation ist kein Ersatz für Sauberkeit!

Die Broschüre "Instrumenten-Aufbereitung richtig gemacht" des Arbeitskreis Instrumenten-Aufbereitung dient als Anhalt.

Reda Instrumente GmbH
78532 Tuttlingen

IMPORTANT INFORMATION CONCERNING PREPARING AND STERILIZING SURGICAL INSTRUMENTS

Dear Sirs,
please read the following instructions very carefully before using the instruments.

1. INITIAL USE

All instruments which are being used for the first time must be thoroughly cleaned, rinsed and then sterilized before using.

2. TREATING INSTRUMENTS AFTER USAGE

- a.) The instruments might be immediately thoroughly cleaned and disinfected. Please follow the manufacturer's instructions when using cleaning agents and disinfectants.
- b.) Instruments which may be dismantled must be cleaned and disinfected after being taken apart.
- c.) Cleaning may be carried out either manually or with a machine. Care should be taken that only cleaning agents and disinfectants are used, which are changed daily.
- d.) Following chemical disinfection and manual cleaning, all instruments must always be thoroughly rinsed under running water.
- e.) The temperature of water used in a machine for cleaning should not exceed 45°C.
- f.) Whether cleaning is carried out manually or by machine, we especially ask you to ensure that the correct dosage for cleaning solutions or the correct combination of disinfectant and cleaning solution, is employed. Similar importance should be applied to the length of time the agents require to perform properly and to the temperature set.
- g.) Hinged instruments should be opened before cleaning.
- h.) Please ensure that the perforated instrument trays, when loaded, do not exceed 10 kg in weight.
- i.) Please take care that when instruments are being cleaned they are arranged proper in a manne that fluids can circulate freely.
- j.) Deposits remaining after the cleaning process must be completely removed in the first rinse which now follows. The optimum temperature for final rinsing has proved to be between 70° and 90° C. Please use only purified water in this final cleaning stage.
- k.) The instruments must be carefully dried after cleaning and rinsing is completed.
- l.) Moving parts and the cutting edges of shears and scissors must be treated with preservatives which are both suitable and physiologically safe.

3. TESTING FOR CORRECT FUNCTIONING

- a.) Instruments must be carefully and thoroughly checked before every occasion that they are used.

- b.) After each time they are cleaned, the instruments must be macroscopically clean, i.e., visibly free from proteinbased residues and other soiling.
- c.) Care should be taken so that cracks, breakages and corrosion are noticed.
- d.) Instruments with flecks should be separated and taken out for special treatment.
- e.) All moving parts as well as working tips and blades should be checked with special care.
- f.) Checking should be carried out according to the extent to which the instruments will be used.
- g.) Instruments which are in any way defective or damaged should be immediately sorted out from the others.

4. STERILIZATION

- a.) All stainless steel surgical instruments supplied by us may be sterilized in an autoclave.
- b.) Please follow the manufacturer's operating instructions when using autoclave. All machines used must comply with all current quality and other standards.
- c.) Instruments are being sterilized/ autoclaved at a temperature of 134°C.
- d.) Sterilization packing material must comply with all current standards.
- e.) Instruments with ratchets or self-retaining mechanisms should be sterilized opened or in the first ratchet position.
- f.) Please ensure that perforated instrument trays, when loaded do not exceed 10 kg in weight.

5. IN GENERAL

- a.) All surgical instruments supplied by us have been thoroughly inspected before dispatch and leave our factory in perfect condition. Damage which can arise as a result of transporting, cleaning, preserving, sterilizing or storing, must be prevented.
- b.) Please handle surgical instruments always with the utmost care.
- c.) Instruments must be stored in a clean and dry place.
- d.) If you have any queries or problems please contact us at any time:

We should like to point out that, if the above-mentioned directions are not followed or the instruments supplied by us are not properly used, all guarantee claims become void and any consequences must be borne by yourselves.

SUGERENCIAS PARA LA LIMPIEZA, ESTERILIZACIÓN Y MANTENIMIENTO DE INSTRUMENTOS QUIRÚRGICOS

ENJUAGADO

Tras el uso enjuagar enseguida los instrumentos bajo un chorro de agua caliente (no hirviendo). El enjuagado debe servir para quitar los residuos de sangre, mucosas y tejidos.

LIMPIEZA

Si la limpieza no se efectúa inmediatamente después del enjuagado, los instrumentos tienen que sumergirse en una solución de agua y detergente con PH neutro (7)

Para los instrumentos muy delicados (algunos tipos de porta agujas o tijeras se aconseja una limpieza manual: ver punto "C").

a.- Limpieza en la pila de ultrasonido

Los instrumentos tienen que estar en la pila el tiempo necesario recomendado por el fabricante para efectuar el ciclo del lavado, generalmente de 5 a 10 minutos.

Los instrumentos con bisagras o juntas (articulaciones) tienen que sumergirse en la pileta en posición abierta.

Asegurarse de que las hojas afiladas de las tijeras, bisturíes para gingivectomía, curetas, etc. no estén en contacto con otros instrumentos.

Todos los instrumentos deben estar completamente sumergidos en la solución de lavado.

No poner instrumentos de diferentes metales (acero inoxidable, instrumentos cromados, latón, etc.) en el mismo ciclo de lavado.

Cambiar a menudo la solución para el lavado, como mínimo todas las veces que lo recomienda el fabricante de la pila de ultrasonidos.

Enjuagar concienzudamente los instrumentos con agua corriente tras lavado con ultrasonidos para quitar los residuos de la solución de lavado.

b.- Limpieza con lavadora

Seguir las indicaciones del fabricante. Asegurarse de que los instrumentos hayan sido lubricados tras el último ciclo de lavado y antes del ciclo de esterilización.

c.- Limpieza manual

La mayor parte de los fabricantes de instrumentos indican el lavado con los ultrasonidos como el modo mejor y más eficaz para limpiar los instrumentos quirúrgicos, especialmente los que tienen bisagras, cierres y en general articulaciones. Si la limpieza con los ultrasonidos no es posible, se aconseja usar el método siguiente:

- Usar cepillos rígidos de plástico, nylon, etc.
- Cepillar concienzudamente los instrumentos más delicados y, si es posible, enjuagar, limpiar y esterilizar estos instrumentos separadamente.
- Verificar que toda la superficie de estos instrumentos esté limpia.
- Tras haber cepillado los instrumentos, enjuagarlos bajo el chorro de agua corriente.
- Durante el enjuagado abrir y cerrar las tijeras, las pinzas hemostáticas, los porta agujas y los demás instrumentos con bisagras o juntas y asegurarse de que las partes internas de las bisagras estén perfectamente enjuagadas como la superficie externa del instrumento.

SECADO, LUBRIFICACIÓN E INSPECCIÓN

Tras las operaciones de limpieza y de enjuagado, los instrumentos quirúrgicos tienen que ser secados perfectamente.

Todos los instrumentos con juntas o bisagras (acción "metal contra metal") como tijeras, pinzas hemostáticas, porta agujas, fórceps de extracción, etc., tienen que ser lubricados. Se aconsejan lubricantes específicos para el instrumental quirúrgico. No usar aceites o lubricantes industriales.

A este punto es buena norma inspeccionar el estado de cada instrumento y verificar el funcionamiento según el uso específico. Controlar y asegurarse de que:

- Las hojas de las tijeras estén lisas de arriba abajo y de que, una vez cerradas, no hagan juego. Probar las tijeras cortando gasa muy fina. Tres cuartas parte de la hoja tienen que cortar la gasa sin retenerla.

- Las puntas de las pinzas estén al mismo nivel.
- Las pinzas hemostáticas y los porta agujas no dejen pasar la luz entre las puntas cuando estén cerradas, se abran y cierren fácilmente y que las bisagras no estén demasiado flojas.
- Controlar el desgaste de la porta agujas sobre la superficie interna de las puntas.
- Las cánulas metálicas de aspiración estén bien limpias en su interior.
- Los instrumentos cortantes y los bisturíes tengan las hojas bien afiladas y no estropeadas.

ESTERILIZACIÓN EN AUTOCLAVE

Tras haber enjuagado, limpiado, secado, lubricado e inspeccionado los instrumentos, éstos pueden ser preparados para la esterilización separadamente o en serie.

Instrumentos individuales:

Las bolsas especiales monouso son el ideal para contener los instrumentos. Asegurarse de que las bolsas que contendrán los instrumentos con cierres y articulaciones (pinzas hemostáticas, porta agujas, etc.) sean lo bastante grandes como para contener los citados instrumentos en posición abierta.

Instrumentos en serie:

Poner los instrumentos en los especiales cestos o bandejas de acero inoxidable. Poner los instrumentos más pesados en la parte inferior cuando sean necesarias varias bandejas.

No cerrar nunca los instrumentos durante el ciclo en autoclave. Un instrumento cerrado no estará nunca bien esterilizado, ya que el vapor no puede penetrar en la parte de cierre a contacto "metal contra metal". En el instrumento podría además romperse en la parte de la bisagra a causa de la expansión del metal debida al calor durante el ciclo del autoclave.

No cargar demasiado la cámara del autoclave ya que algunos instrumentos podrían formar "zonas de sombra" sobre otros en los que el vapor no penetraría.

ATENCIÓN

Al final del ciclo de esterilización - antes del ciclo de secado - abrir ligeramente la portezuela del autoclave y preceder con el ciclo desecado según las instrucciones del fabricante. Si la portezuela del autoclave se abre completamente antes del ciclo de secado, el aire frío de la habitación entraría en la cámara del autoclave causando la formación de condensación sobre los instrumentos y de consecuencia aparecerían las manchas de agua que vemos a menudo en los mismos.

ESTERILIZACIÓN EN FRÍO:

La mayor parte de las soluciones para la esterilización en frío esterilizan los instrumentos completamente tras 10 horas de inmersión. Esta acción química prolongada puede ser más perjudicial para los instrumentos que el ciclo normal de 20 minutos en autoclave.

Si los instrumentos tienen necesidad de ser simplemente "desinfectados", el proceso en frío es adecuado, ya que la desinfección tiene lugar en 10 minutos solamente.

Recuerde bien la diferencia entre:

ESTÉRIL - término absoluto (ningún organismo logra sobrevivir) y

DESINFECTADO - perfectamente limpio.

Usen siempre la técnica más adecuada de esterilización/limpieza de los instrumentos según el uso que se haga posteriormente de ellos.

Recuerden que la esterilización de los instrumentos no sustituye la limpieza de los mismos.

Recomendamos no volver a usar ni esterilizar los artículos de un solo uso. Si se tratan en el modo correcto los instrumentos construidos con las modernas aleaciones inoxidables pueden durar muchos años.

INDICAZIONI PER LA CURA, PULITURA E LA STERILIZZAZIONE DELLO STRUMENTARIO CHIRURGICO RISTERILIZZABILE

Misure preventive anticorrosione

- 1) Raggruppare accuratamente gli strumenti correttamente confezionati e sterilizzati prima dell'operazione; selezionarli secondo l'intervento. Verificare sempre che la confezione esterna sia integra e che lo strumento stesso non sia danneggiato.
- 2) Assicurarli tramite l'indicatore di sterilizzazione collocato all'interno del vaglio che il contenuto sia stato sterilizzato.
- 3) Disporre gli strumenti seguendo l'ordine di utilizzo durante l'operazione; lasciare gli strumenti non necessari nel vaglio; predisporre gli strumenti solo immediatamente prima dell'operazione.
- 4) Nel corso dell'operazione rimuovere dagli strumenti sangue ed altri materiali biologici; dopo l'uso, riporre gli strumenti nel corretto alloggiamento.
- 5) Risciacquare opportunamente gli strumenti cavi, al fine di evitare l'adesione di sangue e polvere d'osso.
- 6) Per la pulitura degli strumenti utilizzare una soluzione lattata o una soluzione salina, ma non immergerli nelle suddette soluzioni.
- 7) Iniziare l'operazione di pulitura subito dopo l'intervento. Strumenti utilizzati su pazienti con possibili infezioni: smaltire in modo analogo, eliminando sangue, polvere d'osso parti di tessuto in eccesso.
- 8) Pulire gli strumenti in un luogo previsto nell'ambito della sala operatoria.

Nel caso in cui gli strumenti vadano collocati direttamente nella centrale di sterilizzazione, è necessario dapprima coprirli, per evitare il rischio di contaminazione ai danni del personale o dell'ambiente circostante.

Disinfezione

Durante l'uso di disinfettanti chimici è necessario osservare scrupolosamente le indicazioni del produttore; utilizzare le soluzioni sempre previa diluizione. Nella fase termica di disinfezione con acqua bollente assicurarsi che l'acqua sia priva di corpi estranei.

Pulitura

Indipendentemente dal metodo utilizzato per la pulitura (meccanico o manuale) si raccomanda di verificare attentamente quale detergente vada utilizzato con ciascun metodo. Valori pH consigliati: tra 7,0 e 8,5.

1) Pulitura meccanica

Osservare scrupolosamente le istruzioni d'uso fornite dal produttore della macchina pulitrice. Predisporre gli

strumenti per la pulitura meccanica. Tutti gli strumenti appuntiti e delicati dovrebbero essere puliti manualmente.

Non sovraccaricare i vagli, mettere gli strumenti pesanti sul fondo del vaglio. Se necessario, immergere e risciacquare gli strumenti molto sporchi (strumenti cavi), prima di collocarli nella lavatrice.

2) Pulitura ad ultrasuoni

(fa parte dei metodi di pulitura meccanica)

Prima di inserire uno strumento nel bagno ad ultrasuoni, rimuovere i materiali organici in eccesso. I bagni ad ultrasuoni sono consigliati per le filettatrici o gli strumenti con solchi profondi. L'ultrasuono deve essere seguito da un programma di risciacquo normale.

3) Pulitura manuale

Richiede diverse spazzole in nylon, una canna da soffio ed un ugello da soffio/ un dispositivo ad aria compressa pulito, detergenti e solventi come per la pulitura meccanica.

Per gli additivi di pulitura osservare le indicazioni fornite dal produttore.

Per la pulitura degli strumenti dotati di cannula, passare più volte lo spazzolino di nylon attraverso la cannula eseguendo movimenti rotatori (non utilizzare spazzole in lana d'acciaio/metallo) fino alla completa rimozione dei residui eliminabili con questo metodo.

Soffiare poi con aria compressa nella cannula.

4) Asciugatura

Ogni strumento deve essere asciugato completamente sia internamente che esternamente per evitare la formazione di ruggine o malfunzionamenti.

Indicazioni per la sterilizzazione della strumentazione

Pulire immediatamente ed asciugare bene gli strumenti usati, non utilizzare detergenti e disinfettanti con additivi fortemente acidi o alcalini (ad es. soda, soda caustica o acidi)!

Sterilizzare la strumentazione solo a vapore A 134°!

Prima della sterilizzazione, assicurarsi che gli strumenti siano perfettamente funzionanti ed integri. La sterilizzazione non sostituisce la pulitura.

Markierungs- und Messinstrumente
 Marking and Measuring Instruments
 Instrumentos para marcar y medir
 Strumenti per marcare e misurare



03340-10	10 cm	4"
03340-15	15 cm	6"
03340-20	20 cm	8"
03340-30	30 cm	11 ³ / ₄ "
03340-50	50 cm	19 ³ / ₄ "

Markierungsinstrumente
 Marking Instruments
 Instrumentos para marcar
 Strumenti per marcare



03385-16 16 cm, 6¹/₄"
 03385-26 26 cm, 10"



PITANGUY
 03370-16
 16 cm, 6¹/₄"



D'ASSUMPCAO
 03380-30
 30 cm, 12"



LOCKWOOD
 03390-30
 32,5 cm, 12³/₄"

Markierungs- und Messinstrumente
 Marking and Measuring Instruments
 Instrumentos para marcar y medir
 Strumenti per marcare e misurare



FREEMAN

- 03500-34 Ø 34 mm, 1³/₈"
- 03500-36 Ø 36 mm, 1⁵/₈"
- 03500-38 Ø 38 mm, 1¹/₂"
- 03500-42 Ø 42 mm, 1²/₃"
- 03500-45 Ø 45 mm, 1³/₄"
- 03500-50 Ø 50 mm, 2"



FREEMAN

- 03520-34 Ø 34 / 36 mm
- 03520-38 Ø 38 / 42 mm
- 03520-45 Ø 45 / 50 mm



GROSSMAN

- 03505-00
- Ø 40, 44, 48, 52

ALUMINIUM



FREEMAN

- 03501-34 Ø 34 / 36 mm
- 03501-38 Ø 38 / 42 mm
- 03501-45 Ø 45 / 50 mm



FREEMAN

- 03530-34 Ø 34 mm, 1³/₈"
- 03530-36 Ø 36 mm, 1⁵/₈"
- 03530-38 Ø 38 mm, 1¹/₂"
- 03530-42 Ø 42 mm, 1²/₃"
- 03530-45 Ø 45 mm, 1³/₄"
- 03530-50 Ø 50 mm, 2"



- 03540-32 Ø 32 mm, 1¹/₄"
- 03540-37 Ø 37 mm, 1¹/₂"
- 03540-43 Ø 43 mm, 1³/₄"

Markierungs- und Messinstrumente
 Marking and Measuring Instruments
 Instrumentos para marcar y medir
 Strumenti per marcare e misurare



McKISSOCK
 14 cm, 5 1/2"

- 03400-38 38 mm, 1 1/2"
- 03400-42 42 mm, 1 2/3"
- 03400-45 45 mm, 1 3/4"

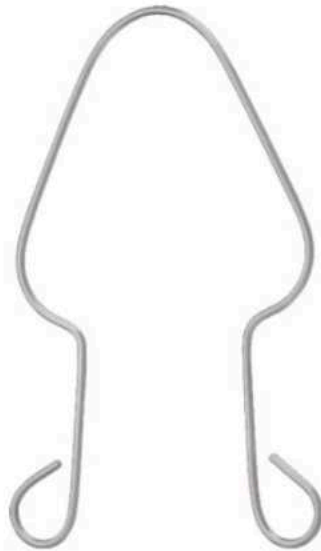

ACKERMANN
 10 cm, 4"

- 03550-14 140 mm, 5 1/2"
- 03550-16 160 mm, 6 1/4"



HALPREN

- 03560-34 34 mm, 1 1/2"
- 03560-38 38 mm, 1 2/3"
- 03560-42 42 mm, 1 3/4"



CASTROVIEJO
 43583-07 9 cm, 3 1/2"
 43583-18 18 cm, 7"

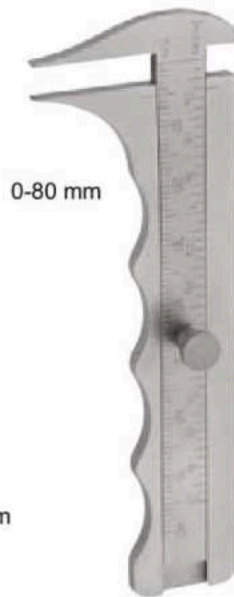

JAMESON
 43585-00
 9,5 cm, 3 3/4"



COLLIER
 73193-30
 30 cm, 11 3/4"

Dermatome
 Dermatome
 Dermàtomo
 Dermatomo



SCHINK
 07490-00
 30 cm, 11³/₄"

compl.
 mit/with/con
 07490-01 (1) Stk./pcs
 07490-02 (2) Stk./pcs



07490-01

Ersatzklinge
 Spare blade
 Hoja de repuesto
 Lama di ricambio per dermatomo

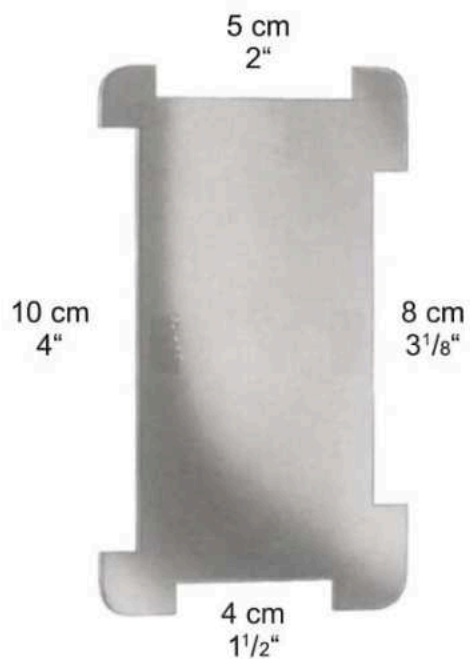

07490-02

Spannplatte
 Skin straightening plate
 Placa para extender la piel
 Placca per stendipelle

Dermatome
Dermatome
Dermátomo
Dermatomo



HUMBY
07495-31
31 cm, 12¹/₄"



SILVER
07498-00
19 cm, 7¹/₂"



WATSON
07499-00
30 cm, 11³/₄"

Ersatzklingen, unsteril / Spare blade, non sterile
Hoja de repuesto, no esteril / Lama di ricambio, non sterile

07496-31

07296-00

07499-01

Skalpellgriffe
Scalpel Handles
Mangos de bisturíes
Manici per lama bisturi

passend zu den Klängen
for blades
para las hojas
per lama bisturi

(A) No. 10, 11, 12, 13, 14, 15, 16, 17, 18, 19



07103-00
Fig. 3

(A)



07103-01
Fig. 3 grad

(A)



07103-02
Fig. 3 L

(A)



07109-03
Fig. 3 L

(A)

Skalpellgriffe
 Scalpel Handles
 Mangos de bisturíes
 Manici per lama bisturi

passend zu den Klängen
 for blades
 para las hojas
 per lama bisturi

(A) No. 10, 11, 12, 13, 14, 15, 16, 17, 18, 19

(B) No. 20, 21, 22, 23, 24, 25



07104-00
 Fig. 4

(B)



07104-02
 Fig. 4 L

(B)



07105-02
 Fig. 4 L

(B)



07106-01
 Fig. 3

(A)

Skalpellgriffe
Scalpel Handles
Mangos de bisturíes
Manici per lama bisturi

passend zu den Klängen
for blades
para las hojas
per lama bisturi

(A) No. 10, 11, 12, 13, 14, 15, 16, 17, 18, 19

(B) No. 20, 21, 22, 23, 24, 25



07107-00
Fig. 7

(A)



07107-01
Fig. 7K

(A)



07108-00
Fig. 8

(B)

Mini-Skalpellgriffe/Skalpellklingen
Scalpel Handles
Mangos de bisturíes
Manici per lama bisturi/lame per bisturi



07109-10 10,0 cm, 4"
07109-13 13,0 cm, 5¹/₈"
07109-15 15,5 cm, 6"



07161-00 07162-00 07165-00 07167-00

Packung mit 10 Stück
box of 10
en cajas de 10 unidades
confezione di 10 pezzi

Skalpelli
Scalpel Handles
Mangos de bisturíes
Manici per lama bisturi



LANDOLT
93385-21 21 cm, 8 1/4"
93385-25 25 cm, 10"

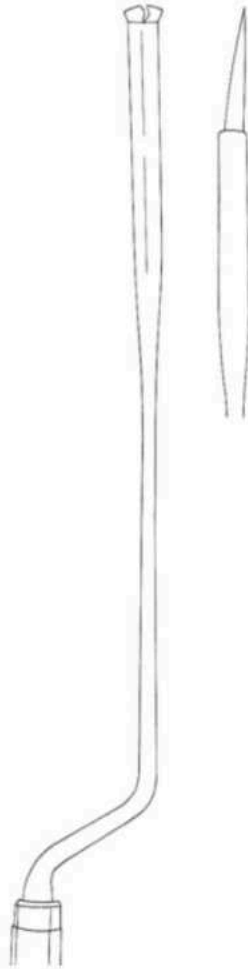

93390-21 21 cm, 8 1/4"

Präparierscheren
Dissecting Scissors
Tijeras de disección
Forbici per dissezione



MAYO



09160-14 14 cm, 5 1/2"
09164-14 TC 14 cm, 5 1/2"
09962-14 SC 14 cm, 5 1/2"



09161-14
09165-14 TC
09963-14 SC

09160-17 17 cm, 6 3/4"
09164-17 TC 17 cm, 6 3/4"
09962-17 SC 17 cm, 6 3/4"

09161-17
09165-17 TC
09963-17 SC

Präparierscheren
 Dissecting Scissors
 Tijeras de disección
 Forbici per dissezione



MAYO-STILLE



09170-15 15 cm, 6"
09174-15 TC 15 cm, 6"
09964-15 SC 15 cm, 6"



09171-15
09175-15 TC
09965-15 SC



09170-17 17 cm, 6³/₄"
09174-17 TC 17 cm, 6³/₄"
09964-17 SC 17 cm, 6³/₄"



09171-17
09175-17 TC
09965-17 SC

Präparierscheren
Dissecting Scissors
Tijeras de disección
Forbici per dissezione



LEXER



09190-16

16 cm, 6¹/₄"

09194-16 TC

16 cm, 6¹/₄"



09191-16

09195-16 TC



LEXER-BABY



09202-10

10 cm, 4"

09206-10 TC

10 cm, 4"



09203-10

09207-10 TC

Präparierscheren
 Dissecting Scissors
 Tijeras de disección
 Forbici per dissezione



METZENBAUM



09280-12	12 cm, 4 ³ / ₄ "	09281-12
09284-12 TC	12 cm, 4³/₄"	09285-12 TC
09966-11 SC	12 cm, 4³/₄"	09967-11 SC
09280-15	15 cm, 6"	09281-15
09284-15 TC	15 cm, 6"	09285-15 TC
09970-14 SC	15 cm, 6"	09971-14 SC
09280-18	18 cm, 7"	09281-18
09284-18 TC	18 cm, 7"	09285-18 TC
09970-18 SC	18 cm, 7"	09971-18 SC
09280-20	20 cm, 8"	09281-20
09284-20 TC	20 cm, 8"	09285-20 TC
09970-20 SC	20 cm, 8"	09971-20 SC
09280-23	23 cm, 9"	09281-23
09284-23 TC	23 cm, 9"	09285-23 TC
09970-23 SC	23 cm, 9"	09971-23 SC

Präparierscheren
Dissecting Scissors
Tijeras de disección
Forbici per dissezione



METZENBAUM



09270-15
09270-18

15 cm, 6"
18 cm, 7"



09271-15
09271-18

09274-15 TC
09274-18 TC

15 cm, 6"
18 cm, 7"

09275-15 TC
09275-18 TC



METZENBAUM-FINO



09282-15
09286-15 TC

15 cm, 6"
15 cm, 6"



09283-15
09287-15 TC

09282-18
09286-18 TC

18 cm, 7"
18 cm, 7"

09283-18
09287-18 TC

09282-20
09286-20 TC

20 cm, 8"
20 cm, 8"

09283-20
09287-20 TC

09282-23
09286-23 TC

23 cm, 9"
23 cm, 9"

09283-23
09287-23 TC

Präparierscheren
Dissecting Scissors
Tijeras de disección
Forbici per dissezione



SANVENERO



09302-14

14 cm, 5 1/2"



09303-14



JOSEPH



09304-14

14 cm, 5 1/2"



09305-14

Präparierscheren
Dissecting Scissors
Tijeras de disección
Forbici per dissezione



09310-12	12 cm, 4 ³ / ₄ "
09314-12 TC	12 cm, 4³/₄"
09995-12 SC	12 cm, 4³/₄"
09310-15	15 cm, 6"

KILNER (RAGNELL)



REYNOLDS (JAMESON)	
09321-15	15 cm, 6"
09993-15 SC	15 cm, 6"
09321-18	18 cm, 7"



KELLY		
09540-16	16 cm, 6 ¹ / ₄ "	09541-16
09542-16 TC	16 cm, 6¹/₄"	09543-16 TC
09544-16 SC	16 cm, 6¹/₄"	09545-16 SC

Feine Scheren
 Delicate Scissors
 Tijeras finas
 Forbici delicate

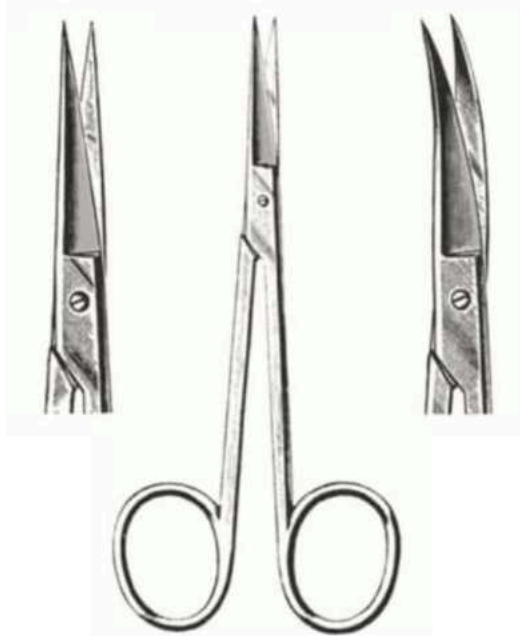

IRIS

09340-09	9 cm, 3 ¹ / ₂ "	09341-09
09340-10	10 cm, 4"	09341-10
09340-11	11 cm, 4 ³ / ₈ "	09341-11
09344-11 TC	11 cm, 4³/₈"	09345-11 TC
09980-11 SC	11 cm, 4³/₈"	09981-11 SC



BONN

09342-08 8 cm, 3¹/₈" 09343-08

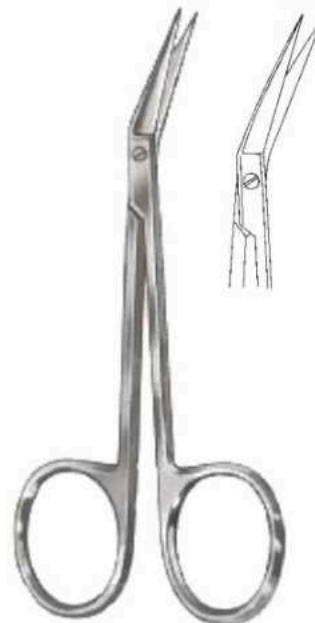

IRIS

09346-11
 11 cm, 4³/₈"

Feine Scheren
Delicate Scissors
Tijeras finas
Forbici delicate



KNAPP
10 cm, 4"



09348-01



09348-02



09348-03



09348-04



09348-05



09348-06

Feine Scheren
Delicate Scissors
Tijeras finas
Forbici delicate



LITTLER
09349-12
12 cm, 4³/₄"



GRAEFE
09350-10
10 cm, 4"

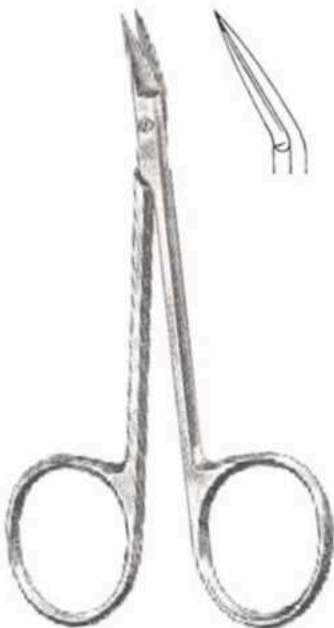

CONVERSE/WILMER/WALTER
09352-10
10 cm, 4"



COTTLE
09358-11
11 cm, 4³/₈"

Feine Scheren
Delicate Scissors
Tijeras finas
Forbici delicate



GRADLE
09350-09 9,5 cm, 3³/₄" 09351-09



09352-09 9,5 cm, 3³/₄" 09353-09



09354-10 10 cm, 4" 09355-10



09356-10 10 cm, 4" 09357-10

Feine Scheren
 Delicate Scissors
 Tijeras finas
 Forbici delicate



STEVENS
 11 cm, 4³/₈"

spitz
 sharp
 agudo
 acuti



09360-11
09984-11SC



09361-11
09985-11 SC

stumpf
 blunt
 romo
 smussi



09362-11



09363-11

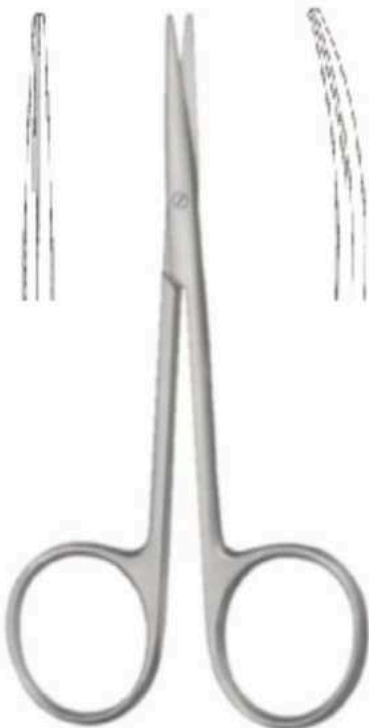

STRABISMUS

09370-11 11 cm, 4³/₈" 09371-11
09374-11TC 11 cm, 4³/₈" 09375-11TC

Feine Scheren
Delicate Scissors
Tijeras finas
Forbici delicate



WAGNER
12 cm, 4³/₄"



09828-12



09826-12



09824-12
09982-12SC



WAGNER
12 cm, 4³/₄"



09823-12



09829-12



09825-12
09983-12 SC

Zahnfleischscheren
Gum Scissors
Tijeras para encias
Forbici gengivali



LA GRANGE
09854-11
11,5 cm, 4 1/2"



CHADWICK
09855-11
11,5 cm, 4 1/2"

Nasenscheren
Nasal Scissors
Tijeras nasales
Forbici nasali



HEYMAN
09401-18 18 cm, 7"



FOMON
09403-15 15 cm, 6"



COTTLE
09405-16 16 cm, 6 1/4"
09405-16TC 16 cm, 6 1/4"



COTTLE-MASING
09406-10 10 cm, 4" 09407-10



FOMON
09617-13 13 cm, 5 1/8"

Fadenscheren
Stitch Scissors
Tijeras para hilos
Forbici taglia fili



SPENCER
09802-09 9 cm, 3¹/₂"
09802-11 11 cm, 4³/₈"



LITTAUER
09804-14
14 cm, 5¹/₂"



O'BRIEN
09805-09
9 cm, 3¹/₂"

Knorpelscheren/Zahnfleischscheren
Cartilage Scissors/Gum Scissors
Tijeras para cartilago/Tijeras para encías
Forbici per cartilagine/Forbici gengivali



MC INDOE
09614-19
19 cm, 7 1/2"

1 Schneide gezahnt
1 blade toothed
1 hoja dentada
1 taglio dentellato



09820-13 GOLDMAN-FOX 09821-13
13 cm, 5 1/8" **09821-13SC**

Face-Lift Scheren
 Face-Lift Scissors
 Face Lift tijeras
 Face Lift forbici



GORNEY



10010-19

19 cm, 7 1/2"



10011-19

10012-19 TC

19 cm, 7 1/2"

10013-19 TC

10014-19 SC

19 cm, 7 1/2"

10015-19 SC



GORNEY-FREEMAN

10061-19

19 cm, 7 1/2"

10061-19 TC

19 cm, 7 1/2"

10061-19 SC

19 cm, 7 1/2"

10061-23

23 cm, 9"

10061-23 TC

23 cm, 9"

10061-23 SC

23 cm, 9"

Face-Lift Scheren
 Face-Lift Scissors
 Face-Lift tijeras
 Face Lift forbici



KAYE

10028-14 TC	14 cm, 5 1/2"	10029-14 TC
10034-14 SC	14 cm, 5 1/2"	10035-14 SC
10030-18 TC	18 cm, 7"	10031-18 TC
10036-18 SC	18 cm, 7"	10037-18 SC
10032-23 TC	23 cm, 9"	10033-23 TC
10038-23 SC	23 cm, 9"	10039-23 SC



PECK-JOSEPH

10044-14	14,5 cm, 5 3/4"	10045-14
10048-14 SC	14,5 cm, 5 3/4"	10049-14 SC



BEUSE

10050-14	14 cm, 5 1/2"	10051-14
10050-18	18 cm, 7"	10051-18

Blepharoplastik Scheren
Blepharoplasty Scissors
Tijeras para blefaroplastia
Forbici per blefaroplastica



GREENBERG-PAR
10201-11 11,5 cm 4¹/₂"
10201-11SC 11,5 cm 4¹/₂"



KAYE
10206-11 11,5 cm, 4¹/₂" 10207-11
10206-11SC 11,5 cm, 4¹/₂" **10207-11SC**

Mikro Scheren
 Micro Scissors
 Micro tijeras
 Micro Forbice



11 cm
 4³/₈"

10202-11

10203-11

14,5 cm
 5³/₄"

10202-14
 10202-14T

10203-14
 10203-14T

18 cm
 7"

10202-18
 10202-18T

10203-18
 10203-18T

21 cm
 8¹/₄"

10202-21
 10202-21T

10203-21
 10203-21T

23 cm
 9"

10202-23

10203-23

T= Titan, titanium, titanio, titanio

Mikro Scheren
Micro Scissors
Micro tijeras
Micro Forbice



18 cm 7"



25°

10220-25

10220-25T

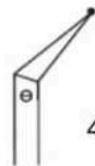

45°

10220-45

10220-45T

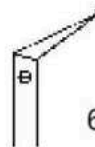

60°

10220-60

10220-60T

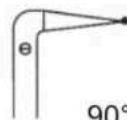

90°

10220-90

10220-90T

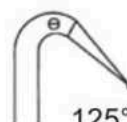

125°





10220-00

10220-00T

T= Titan, titanium, titanio, titanio

Mikro Scheren
Micro Scissors
Micro tijeras
Micro Forbice

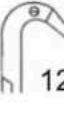

	11 cm 4 ³ / ₈ "	14,5 cm 5 ³ / ₄ "	18 cm 7"	21 cm 8 ¹ / ₄ "	23 cm 9"
 25°	10226-11	10226-14	10226-18 10226-18T	10226-21	10226-23
 45°	10227-11	10227-14	10227-18 10227-18T	10227-21	10227-23
 60°	10228-11	10228-14	10228-18 10228-18T	10228-21	10228-23
 90°	10229-11	10229-14	10229-18 10229-18T	10229-21	10229-23
 125°	10230-11	10230-14	10230-18 10230-18T	10230-21	10230-23

T= Titan, titanium, titanio, titanio

Anatomische und chirurgische Pinzetten
 Dressing and Tissue Forceps
 Pinzas de disección sin/con dientes
 Pinze per dissezione, chirurgiche/anatomiche



STANDARD

USA

STILLE

cm

10,5 4 1/4" 11102-10

11,5 4 1/2" 11102-11

12,0 4 3/4" 11102-12

13,0 5 1/8" 11102-13

14,5 5 3/4" 11102-14

15,0 6" 11102-15

15,5 6" 11102-16

16,0 6 1/4" 11102-17

18,0 7" 11102-18

20,0 8" 11102-20

21,0 8 1/4" 11102-21

11104-12

11104-13

11104-14

11104-15

11104-18

11104-21

11106-13

11106-15

schmal
 narrow
 estrecha
 stretta



POTTS-SMITH

POTTS-SMITH
 1x2

cm

11,5 4 1/2" 11110-11

13,0 5 1/8" 11110-13

14,5 5 3/4" 11110-14 11114-14 TC

16,0 6 1/4" 11110-16 11114-16 TC









18,0 7" 11110-18 11112-18 11116-18 TC 11126-18

20,0 8" 11110-20 11114-20 TC

21,0 8 1/4" 11110-21 11112-21 11116-21 TC 11126-21

25,0 10" 11110-25 11114-25 TC 11112-25 11116-25 TC 11126-25

Chirurgische Pinzetten
Tissue Forceps
Pinzas de disección con dientes
Pinze per dissezione, chirurgiche

				
	1x2	1x2	1x2	1x2
	STANDARD	USA	STILLE	schmal narrow estrecha stretta
cm				
10,5	4 1/4"			
11,5	4 1/2"			11130-11
12,0	4 3/4"	11122-12		
13,0	5 1/8"	11122-13		11130-13
14,5	5 3/4"	11122-14		11130-14
15,0	6"		11124-15	
15,5	6"	11122-15		
16,0	6 1/4"	11120-16		11130-16
18,0	7"	11120-18	11122-18	11130-18
20,0	8"	11120-20		11130-20
21,0	8 1/4"	11122-21		
				
	OEHLER	2x3	3x4	4x5
cm				
11,5	4 1/2"	11140-11		
13,0	5 1/8"	11140-13	11150-13	11160-13
14,5	5 3/4"	11140-14	11150-14	11160-14
16,0	6 1/4"	11132-16 TC	11140-16	11150-16
18,0	7"	11132-18 TC	11140-18	11160-16
20,0	8"	11132-20 TC	11140-20	

Anatomische und chirurgische Pinzetten
 Dressing and Tissue Forceps
 Pinzas de disección sin/con dientes
 Pinze per dissezione, chirurgiche/anatomiche



ADSON

11170-12 12,0 cm, 4³/₄"
 11170-15 15,0 cm, 6"



ADSON

11170-12F 12 cm, 4³/₄"



ADSON

11174-12 TC 12,0 cm, 4³/₄"
 11174-15 TC 15,0 cm, 6"



ADSON micro

11176-12 12,0 cm, 4³/₄"
 11176-15 15,0 cm, 6"



ADSON-DeBAKEY atraumatic
 11177-12
 12,0 cm, 4³/₄"



1x2

ADSON
 11178-12
 12,0 cm, 4³/₄"



2x3

ADSON
 11179-12
 12 cm, 4³/₄"

Chirurgische Pinzetten
Tissue Forceps
Pinzas de disección con dientes
Pinze per dissezione, chirurgiche



1x2

ADSON
11180-12 12,0 cm, 4³/₄"
11180-15 15,0 cm, 6"



1x2

ADSON
11180-12F 12 cm, 4³/₄"



1x2

ADSON
11181-12 TC 12,0 cm, 4³/₄"
11181-15 TC 15,0 cm, 6"



BEASELEY BABCOCK
11182-12 12 cm, 4³/₄"



1x2

ADSON micro
11186-12 12,0 cm, 4³/₄"
11186-15 15,0 cm, 6"



1x2

ADSON
11187-12 12 cm, 4³/₄"

Chirurgische Pinzetten
Tissue Forceps
Pinzas de disección con dientes
Pinze per dissezione, chirurgiche



7x7

ADSON-BROWN

11188-12 12,0 cm, 4³/₄"

11188-15 15,0 cm, 6"

11189-12 TC 12,0 cm, 4³/₄"



7x7

ADSON-BROWN

11188-12F 12 cm, 4³/₄"



7x7

ADSON-BROWN

11191-12 12 cm, 4³/₄"

Anatomische und chirurgische Pinzetten
 Dressing and Tissue Forceps
 Pinzas de disección sin/con dientes
 Pinze per dissezione, chirurgiche/anatomiche



1x2

WAUGH

- 11187-18 18 cm, 7"
- 11187-20 20 cm, 8"
- 11187-25 25 cm, 10"
- 11187-30 30 cm, 11³/₄"



9x9

BROWN

- 11189-15 15,0 cm, 6"
- 11189-20 20,0 cm, 8"
- 11189-25 25,0 cm, 10"



GRAEFE

- 11190-10 10,5 cm, 4.1"



11221-17

CUSHING
 11220-17

- 11224-17 TC**
 17,0 cm, 6³/₄"



1x2

CUSHING
 11222-17

- 11225-17 TC**
 17,0 cm, 6³/₄"



5x6

LERCHE
 11232-15

- 15,0 cm, 6"

Anatomische und chirurgische Pinzetten
 Dressing and Tissue Forceps
 Pinzas de disección sin/con dientes
 Pinze per dissezione, chirurgiche/anatomiche



1x2

FERRIS-SMITH
 11246-18
 18,0 cm, 7"



2x3

FERRIS-SMITH
 11248-18
 18,0 cm, 7"



DUVAL
 11250-14
 14,5 cm, 5 3/4"



COLLIN-DUVAL
 11252-20
 20,0 cm, 8"



Russ. Mod.
 11256-15 15,0 cm, 6"
 11256-20 20,0 cm, 8"
 11256-25 25,0 cm, 10"



1x2

McINDOE
 11257-15
 15,0 cm, 6"



McINDOE
 11258-15 15,0 cm, 6"
 11259-15 TC 15,0 cm, 6"

Anatomische und chirurgische Pinzetten
 Dressing and Tissue Forceps
 Pinzas de disección sin/con dientes
 Pinze per dissezione, chirurgiche/anatomiche



SEMKEN
 11260-12 12,5 cm, 5"
 11260-15 15,5 cm, 6"
 11261-15 TC 15,5 cm, 6"



SEMKEN
 11270-12 12,5 cm, 5"
 11270-15 15,5 cm, 6"
 11271-15 TC 15,5 cm, 6"
 11271-18 TC 18 cm, 7"



GILLIES
 11272-15 15,5 cm, 6"
 11273-15 TC 15,5 cm, 6"



15,5 cm, 6"

11274-06
0,6 mm

11274-08
0,8 mm

11274-10
1,0 mm



GERALD
 11302-17 17,5 cm, 6.9"
 11302-23 23,0 cm, 9"
 11304-17 TC 17,0 cm, 6³/₄"



GERALD
 11303-17
 17,5 cm, 6.9"

Anatomische und chirurgische Pinzetten
 Dressing and Tissue Forceps
 Pinzas de disección sin/con dientes
 Pinze per dissezione, chirurgiche/anatomiche



GERALD
 11305-17
 17,5 cm, 6.9"



GERALD
 11310-17 17,5 cm, 6.9"
 11312-17 TC 17,5 cm, 6.9"



GERALD
 11311-17
 17,5 cm, 6.9"



CUSHING-TAYLOR
 11312-18 TC
 18,5 cm, 7 1/4"



GERALD
 11313-17
 17,5 cm, 6.9"



11314-01



11314-02

TAYLOR
 17 cm, 6 3/4"



11315-01



11315-02

TAYLOR
 17 cm, 6 3/4"

Anatomische und chirurgische Pinzetten
 Dressing and Tissue Forceps
 Pinzas de disección sin/con dientes
 Pinze per dissezione, chirurgiche/anatomiche

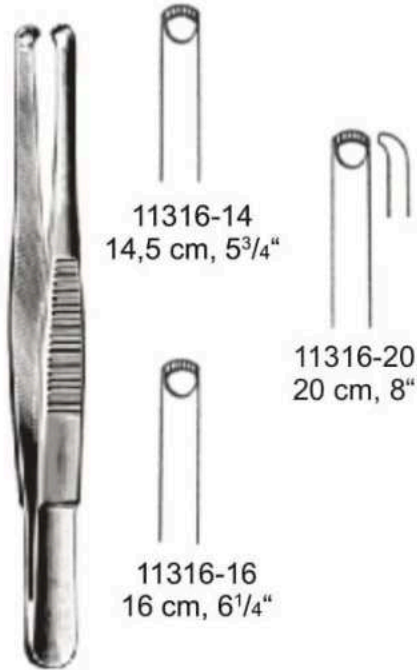

11316-14
14,5 cm, 5³/₄"

11316-20
20 cm, 8"

11316-16
16 cm, 6¹/₄"

DURANTE

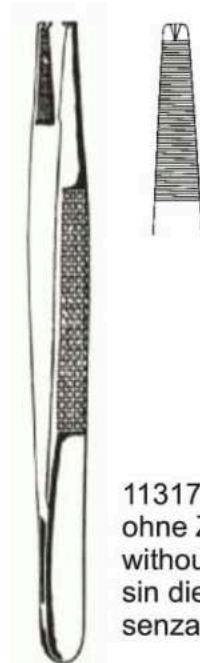

11317-00
ohne Zähne
without teeth
sin dientes
senza denti

11317-12 1x2
11317-23 2x3
11319-12 TC 1x2

BONNEY
18 cm, 7"

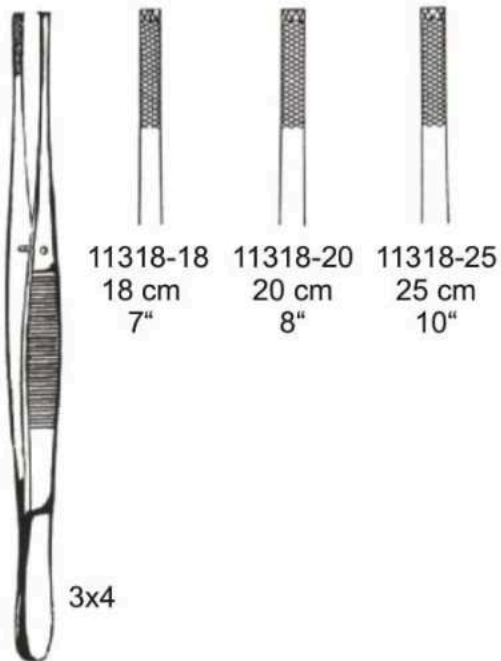

11318-18
18 cm
7"

11318-20
20 cm
8"

11318-25
25 cm
10"

3x4

STILLE-BARRAYA



OCHSNER
11319-14
14,5 cm, 5³/₄"



SINGLEY
11320-18 18 cm, 7"
11320-23 23 cm, 9"

Splitterpinzetten
Splinter Forceps
Pinzas para espinas
Pinze per schegge

Fig.: 1



11401-01
12 cm, 4³/₄"

3



11403-03
12 cm, 4³/₄"

3c



11403-04
11 cm, 4³/₈"

Fig.: 4



11404-04
11 cm, 4³/₈"

5



11405-05
11 cm, 4³/₈"

7



11407-07
12 cm, 4³/₄"

mit Führungsstift
with guide pin

Mikro- Knüpfpinzetten
Micro Suture Tying Forceps
Micro pinzas para ligaduras
Micro pinze per legature



1x2



1x2

	0,3 mm	0,7 mm
12 cm, 4 ³ / ₄ "	12102-12	
	12102-12D	
15 cm, 6"	12102-12T	12108-12T
	12104-15	
18 cm, 7"	12104-15D	
	12104-15T	12108-15T
21 cm, 8 ¹ / ₄ "	12104-18T	12108-18T
		12102-21
23 cm, 9"		12102-21D
		12102-23
		12102-23D
	12104-23T	12108-23T

	0,3 mm	0,7 mm
12 cm, 4 ³ / ₄ "	12103-12	
	12103-12D	
15 cm, 6"	12103-15	
	12103-15D	
18 cm, 7"		12109-18
		12109-18D
21 cm, 8 ¹ / ₄ "		12109-21
		12109-21D
23 cm, 9"		12109-23
		12109-23D

	0,3 mm	0,3 mm
15 cm, 6"	12090-15D	12091-15D
18 cm, 7"	12090-18D	12091-18D
	0,8 mm	0,8 mm
21 cm, 8 ¹ / ₄ "	12090-21D	12091-21D
23 cm, 9"	12090-23D	12091-23D

D = mit diamantiertem Maul
with diamond jaw
con boca de diamante
con morso diamantato
T = Titan, titanium, titanio, titanio

Mikro- Ring-Pinzette mit diamantiertem Maul + TITAN
 Micro Ring Forceps with Diamond Jaw + Titanium
 Micro Pinzas con anillo con boca de diamante + Titanio
 Micro Pinza ad anello con morso diamantato +Titanio



	Ø 1 mm x 0,5 mm	Ø 2 mm x 1 mm
15 cm, 6"	12112-15D	12114-15D
	12112-15T	12114-15T
18 cm, 7"	12112-18D	12114-18D
	12112-18T	12114-18T
21 cm, 8 ¹ / ₄ "	12112-21D	12114-21D
	12112-21T	12114-21T
23 cm, 9"	12112-23D	12114-23D
	12112-23T	12114-23T

D = mit diamantiertem Maul
 with diamond jaw
 con boca de diamante
 con morso diamantato
 T = Titan, titanium, titanio, titanio

Atrauma- Mikro- Pinzette
 Atrauma Micro Forceps
 Micro pinza atraumaticas
 Micro Pinza Atraumatica

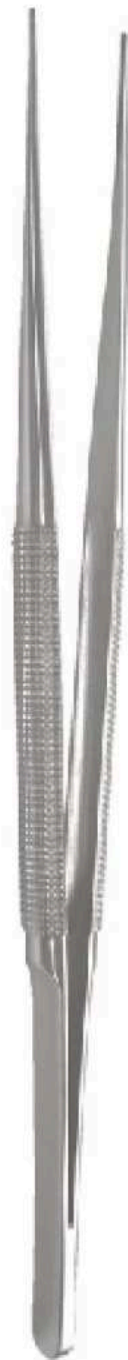

	1,2 mm	2,0 mm
15 cm, 6"	12115-15 12115-15T	12116-15
18 cm, 7"	12115-18 12115-18T	12116-18
21 cm, 8 1/4"	12115-21 12115-21T	12116-21
23 cm, 9"	12115-23 12115-23T	12116-23

T = Titan, titanium, titanio, titanio

De BAKEY

TC Atrauma Pinzette
 TC Atrauma Forceps
 Pinza atraumaticas con TC
 Pinza Atraumatica TC



	1,2 mm	2,0 mm
18 cm, 7"	12117-18 TC	12118-18 TC
21 cm, 8 ¹ / ₄ "	12117-21 TC	12118-21 TC
23 cm, 9"	12117-23 TC	12118-23 TC

De BAKEY TC

Atraumatische Pinzetten
 Atraumatic Tissue Forceps
 Pinzas atraumaticas
 Pinze Atraumatiche



DE BAKEY
 12302-16 16 cm, 6 1/4"
 12302-20 20 cm, 8"
 12302-24 24 cm, 9 1/2"



DE BAKEY
 12306-16 16 cm, 6 1/4"
 12306-20 20 cm, 8"
 12306-24 24 cm, 9 1/2"
 12306-30 30 cm, 11 3/4"



DE BAKEY
 12308-16 16 cm, 6 1/4"
 12308-20 20 cm, 8"
 12308-24 24 cm, 9 1/2"
 12308-30 30 cm, 11 3/4"



DE BAKEY
 12309-16 16 cm, 6 1/4"
 12309-20 20 cm, 8"
 12309-24 24 cm, 9 1/2"
 12309-30 30 cm, 11 3/4"



DE BAKEY
 12304-16 16 cm, 6 1/4"
 12304-20 20 cm, 8"
 12304-24 24 cm, 9 1/2"
 12304-30 30 cm, 11 3/4"

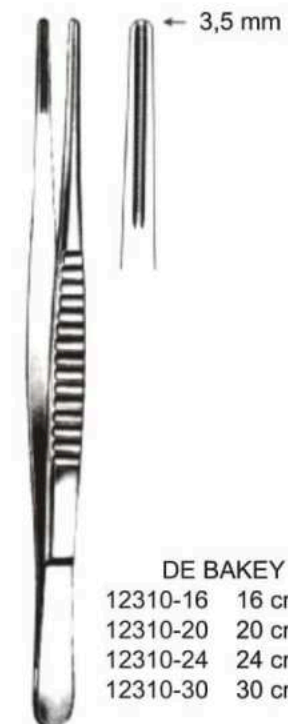

DE BAKEY
 12310-16 16 cm, 6 1/4"
 12310-20 20 cm, 8"
 12310-24 24 cm, 9 1/2"
 12310-30 30 cm, 11 3/4"

Iris Pinzetten
Iris Forceps
Pinzas para iris
Pinze per iride



GRAEFE
43810-10
10 cm, 4"



GRAEFE
43811-10
10 cm, 4"



GRAEFE
43813-10
10 cm, 4"



GRAEFE
43820-10
10 cm, 4"

1x2



GRAEFE
43821-10
10 cm, 4"

1x2



GRAEFE
43823-10
10 cm, 4"

1x2

Iris Pinzetten
Iris Forceps
Pinzas para iris
Pinze per iride



BISHOP-HARMAN
43940-05 8,5 cm, 3.4"
0,5 mm



BISHOP-HARMAN
43940-08 8,5 cm, 3.4"
0,8 mm



BISHOP-HARMAN
43942-05 8,5 cm, 3.4"
0,5 mm

1x2



BISHOP-HARMAN
43942-08 8,5 cm, 3.4"
0,8 mm

1x2

Nahtpinzetten
Suture forceps
Pinzas para sutura
Pinza per sutura



MOD. TUEBINGEN
43950-10
10 cm, 4"



MOD. BONN
43952-10
10 cm, 4" / 0,12 mm



MOD. TUEBINGEN
43953-10
10 cm, 4"

Muskelpinzetten, Nahtpinzetten, Chalazionspinzetten, Cilienpinzetten
 Muscle Forceps, Suture forceps, Forceps for Chalazion, Cilia Forceps
 Pinzas musculares, Pinza para sutura, Pinzas de chalazión, Pinza depilatorias
 Pinza muscolare, Pinza per sutura, Pinze per calazio, Pinza depilatoria



BERKE
 10 cm, 4"

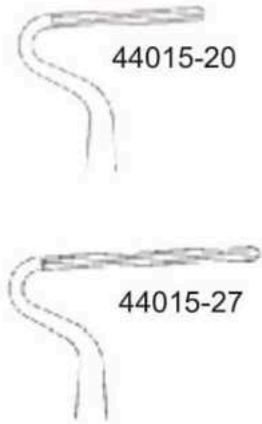

auch mit breitem Griff verfügbar
 also available with broad handle
 también disponible con apoyo ancho
 disponibile con impugnatura larga

- 44150-01 0,12 mm
- 44150-03 0,30 mm
- 44150-05 0,50 mm
- 44150-10 1,00 mm
- 44150-15 1,50 mm

CASTROVIEJO
 10 cm, 4"



DESMARRES
 9 cm, 3 1/2"

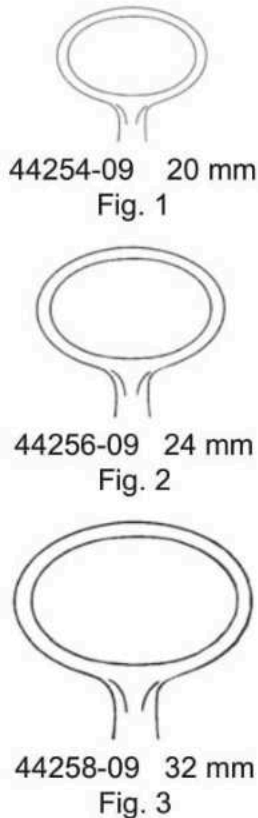

BARRAQUER
 44425-10 10,5 cm, 4.1"

Fixierpinzetten
Fixation forceps
Pinzas para fijación
Pinze fissatrici



GREEN
10 cm, 4"

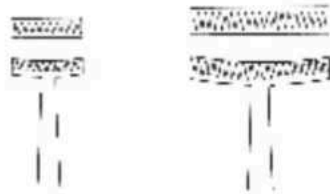

44076-05
5 mm

44076-10
10 mm

ohne Sperre
without catch
sin cierre
senza cremagliera

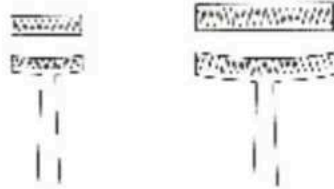

44078-05
5 mm

44078-10
10 mm

mit Sperre
with catch
con cierre
con cremagliera

Ohrpinzetten, Columellapinzette
 Ear Forceps, Columella Forceps
 Pinzas auriculares, Pinza para columela
 Pinze auricolari, Pinza per columella



WILDE (TROELTSCH)
 45201-11 11 cm, 4³/₈"



LUCAE
 45206-14 14 cm, 5¹/₂"
 45206-16 16 cm, 6¹/₄"



COTTLE
 45208-14 14 cm, 5¹/₂"



TROELTSCH
 47151-15 15 cm, 6"
 47151-18 18 cm, 7"



JANSEN-GRUENWALD
 47154-20 20 cm, 8"



COTTLE
 47565-10 10 cm, 4"

Lidplatte
Lid Plate
Placa para párado
Placca per palpebre



JAEGER
43150-11 11 cm, 4³/₈"

Arterienklemmen
Artery Forceps
Pinzas hemostáticas
Pinze emostatiche



HARTMANN
13210-10 10 cm, 4"

Micro - HARTMANN
13214-10 10 cm, 4"



HARTMANN
13211-10 10 cm, 4"

Micro - HARTMANN
13215-10 10 cm, 4"

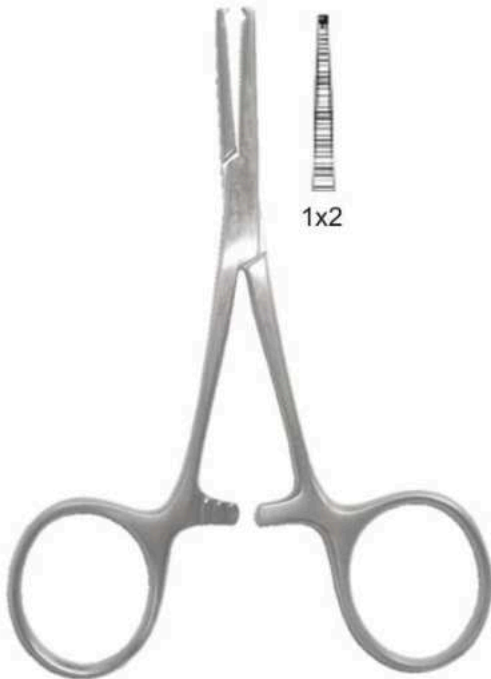

HARTMANN
13212-10 10 cm, 4"

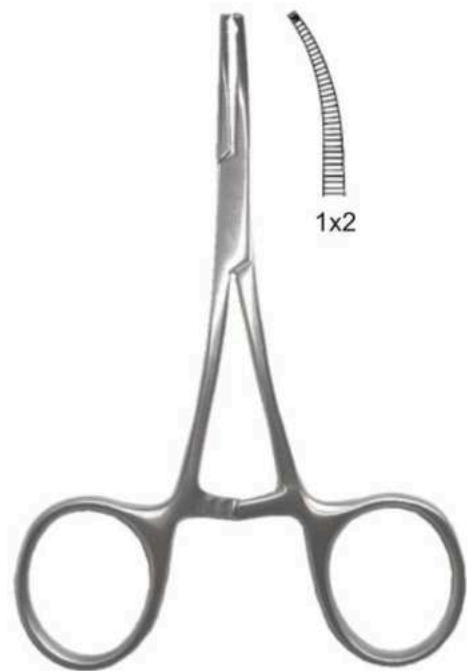

HARTMANN
13213-10 10 cm, 4"

Arterienklemmen
 Artery Forceps
 Pinzas hemostáticas
 Pinze emostatiche



HALSTED-MOSQUITO

13224-12T	13220-12	12,5 cm, 5"	13221-12	13225-12T
	13220-14	14,0 cm, 5½"	13221-14	
	13220-18	18,0 cm, 7"	13221-18	
	13220-21	21,0 cm, 8¼"	13221-21	



HALSTED-MOSQUITO micro

13222-12	12,5 cm, 5"	13223-12
----------	-------------	----------

JACOBSEN micro

13226-12	12,5 cm, 5"	13227-12
----------	-------------	----------

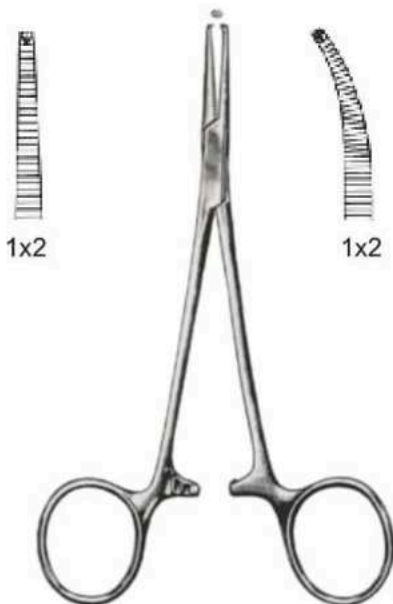

HALSTED-MOSQUITO

13230-12	12,5 cm, 5"	13231-12
13230-14	14,0 cm, 5½"	13231-14
13230-18	18,0 cm, 7"	13231-18
13230-21	21,0 cm, 8¼"	13231-21

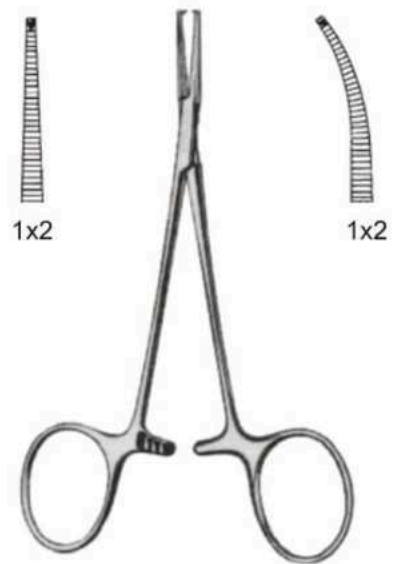

HALSTED-MOSQUITO micro

13232-12	12,5 cm, 5"	13233-12
----------	-------------	----------

Arterienklemmen
Artery Forceps
Pinzas hemostáticas
Pinze emostatiche

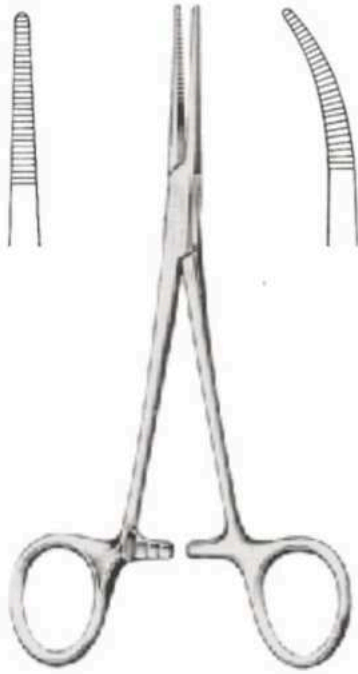

KELLY

13240-14	14 cm, 5 1/2"	13241-14
13240-18	18 cm, 7"	13241-18
13244-14	14 cm, 5 1/2"	13245-14

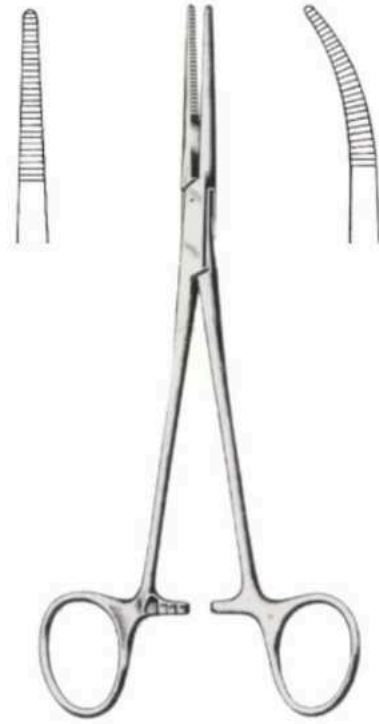

KELLY-RANKIN

13242-16	16 cm, 6 1/4"	13243-16
----------	---------------	----------

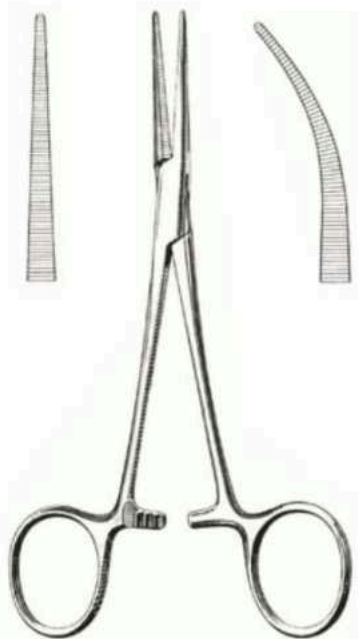

COLLER-CRILE

13256-14	14 cm, 5 1/2"	13257-14
13258-16	16 cm, 6 1/4"	13259-16

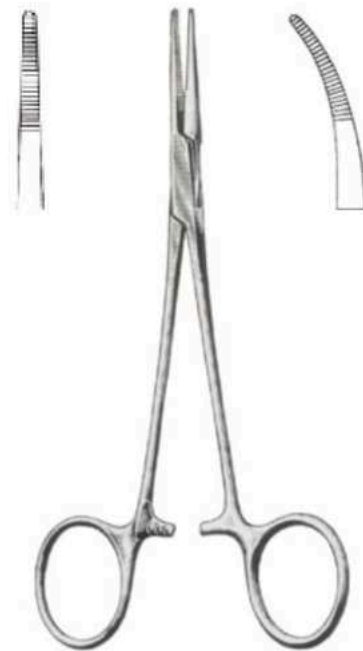

PROVIDENCE-HOSPITAL

13270-14	14 cm, 5 1/2"	13271-14
----------	---------------	----------

Arterienklemmen
 Artery Forceps
 Pinzas hemostáticas
 Pinze emostatiche

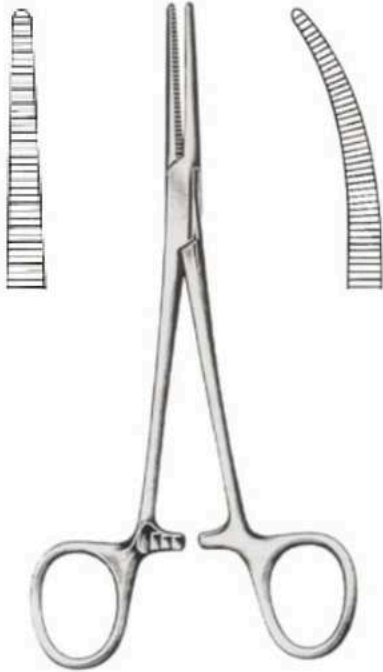

CRILE

- | | | |
|----------|---------------|----------|
| 13250-14 | 14 cm, 5 1/2" | 13251-14 |
| 13250-18 | 18 cm, 7" | 13251-18 |
| 13254-14 | 14 cm, 5 1/2" | 13255-14 |

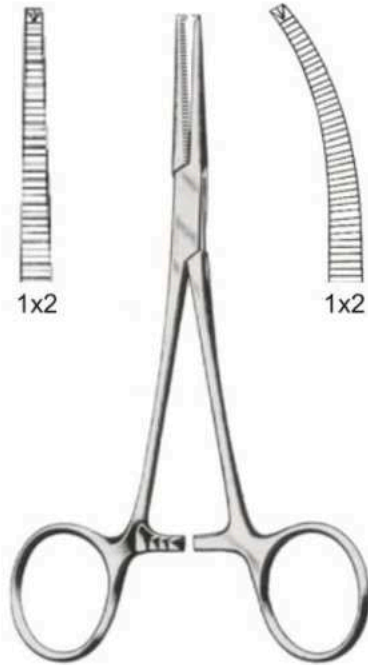

CRILE

- | | | |
|----------|---------------|----------|
| 13260-14 | 14 cm, 5 1/2" | 13261-14 |
|----------|---------------|----------|



CRILE-RANKIN

- | | | |
|----------|---------------|----------|
| 13262-16 | 16 cm, 6 1/4" | 13263-16 |
|----------|---------------|----------|

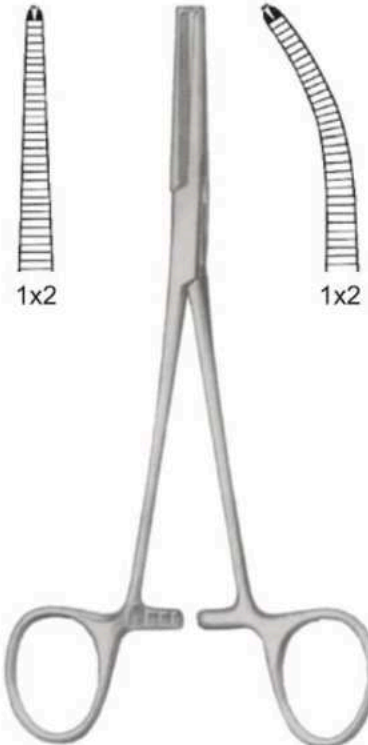

CRILE-RANKIN

- | | | |
|----------|---------------|----------|
| 13264-16 | 16 cm, 6 1/4" | 13265-16 |
|----------|---------------|----------|

Arterienklemmen
 Artery Forceps
 Pinzas hemostáticas
 Pinze emostatiche

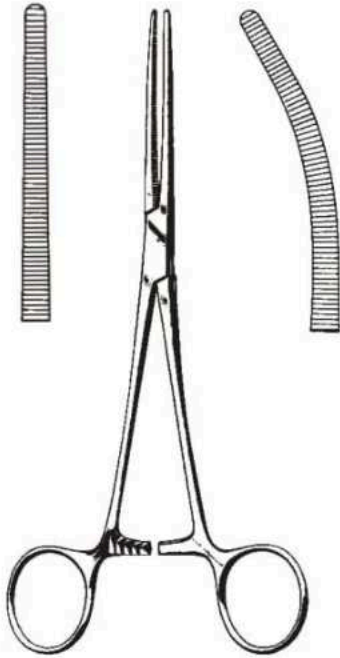

ROCHESTER-PEAN

13310-13 13,0 cm, 5¹/₈" 13311-13
 13310-14 14,0 cm, 5¹/₂" 13311-14
 13310-16 16,0 cm, 6¹/₄" 13311-16

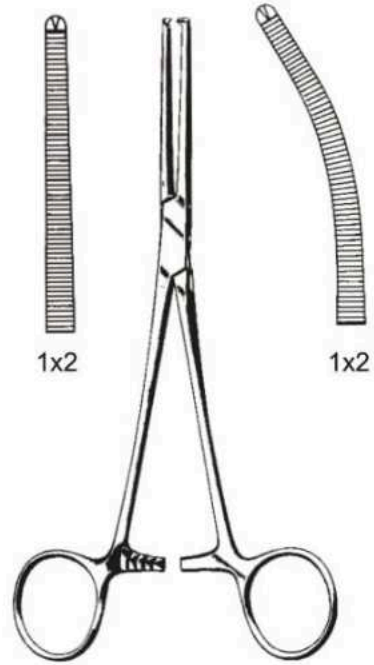

ROCHESTER-OGHSNER

13320-13 13,0 cm, 5¹/₈" 13321-13
 13320-14 14,0 cm, 5¹/₂" 13321-14
 13320-16 16,0 cm, 6¹/₄" 13321-16



LERICHE

13380-15 15 cm, 6" 13381-15

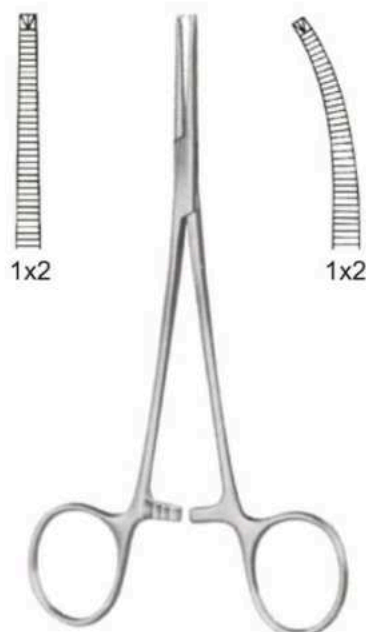

LERICHE

13382-15 15 cm, 6" 13383-15

Arterienklemmen
Artery Forceps
Pinzas hemostáticas
Pinze emostatiche



ADSON
13410-18 18,5 cm, 7¹/₄" 13411-18

Wundhaken
Retractors
Separadores
Divaricatori

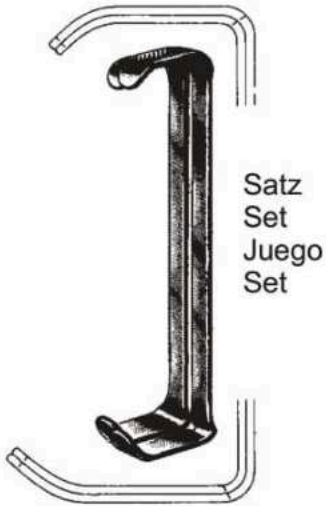

Satz
Set
Juego
Set

FARABEUF
19102-12
12 cm, 4³/₄"

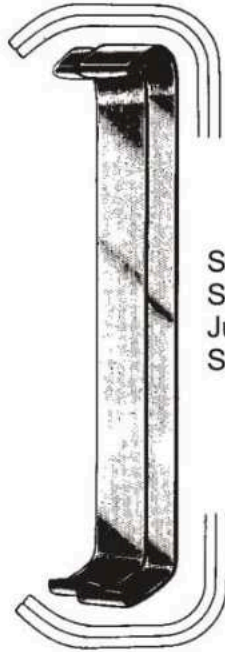

Satz
Set
Juego
Set

FARABEUF
19102-15
15 cm, 6"



ROUX mini
19124-15
14 cm, 5¹/₂"



RAGNELL
19125-14
14 cm, 5¹/₂"

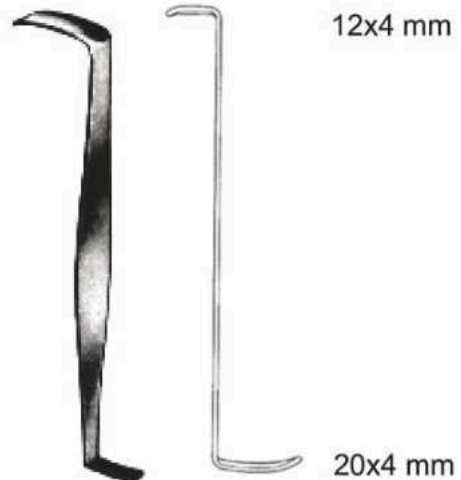

CRILE
19127-11
11 cm, 4¹/₂"

Bauch- und Darmspatel
 Abdominal and Intestinal Spatulas
 Espátulas abdominales e intestinales
 Spatole addominali e intestinali

biegsam
 malleable
 maleables
 malleabili



RIBBON

19168-06	6x200 mm
19168-08	8x200 mm
19168-10	10x200 mm
19168-12	12x200 mm
19168-17	17x200 mm
19168-20	20x200 mm
19168-25	25x200 mm
19169-25	25x250 mm

RIBBON

19170-20	20x330 mm
19170-25	25x330 mm
19170-32	32x330 mm
19170-40	40x330 mm
19170-45	45x330 mm
19170-50	50x330 mm
19170-65	65x330 mm
19170-76	76x330 mm

Wundhaken
Retractors
Separadores
Divaricatori



19 mm

DEAVER
19180-19
19 cm, 7¹/₂"



22 mm

DEAVER
19181-22
21,5 cm, 8¹/₂"



25 mm

DEAVER
19181-25
23 cm, 9"



25 mm

DEAVER
19183-25
30 cm, 11³/₄"



25 mm

DEAVER
19185-25
33 cm, 13"



25 mm

DEAVER
19187-25
36 cm, 14"

Wundhaken
 Retractors
 Separadores
 Divaricatori

25 mm

CL = mit Kaltlicht
 with cold light
 con luz fria
 con luce fredda



FREEMAN
 20 cm/8"

12 mm	19188-12	19188-12CL
25 mm	19188-25	19188-25CL

CL = mit Kaltlicht
 with cold light
 con luz fria
 con luce fredda



DEAVER
 19183-25CL
 30 cm/12"

Feine Wundhaken
Retractors
Separadores
Divaricatori

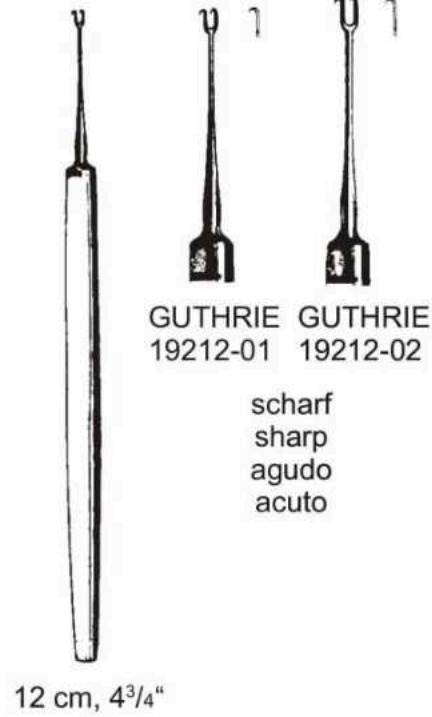
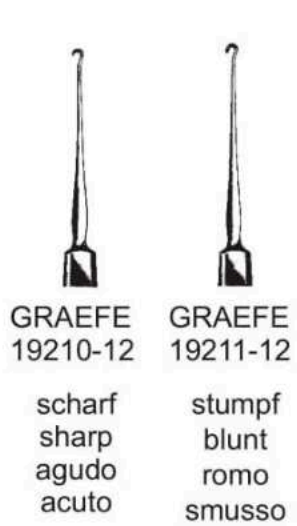

Feine Wundhaken
 Retractors
 Separadores
 Divaricatori



A	B
scharf	stumpf
sharp	blunt
agudo	romo
acuto	smusso

A	19214-13	13 cm, 5 ¹ / ₈ "
A	19214-18	18 cm, 7"
B	19215-13	13 cm, 5 ¹ / ₈ "
B	19215-18	18 cm, 7"

FRAZIER



19215-01



19215-02



19215-03

LAHEY
 12 cm, 4³/₄"



19216-01
 1 mm

19216-02
 2 mm

19216-07
 7 mm

19216-05
 5 mm

19216-10
 10 mm

JOSEPH
 16 cm, 6¹/₄"



19217-03



19217-05



19217-07

KLEINERT-KUTZ
 13 cm, 5¹/₈"

Feine Wundhaken
Retractors
Separadores
Divaricatori



BARSKY
19218-01
15 cm, 6"



BARSKY
19218-02
15 cm, 6"



HUMBY
19218-11
11,5 cm, 4 1/2"

Wundhaken
Retractors
Separadores
Divaricatori

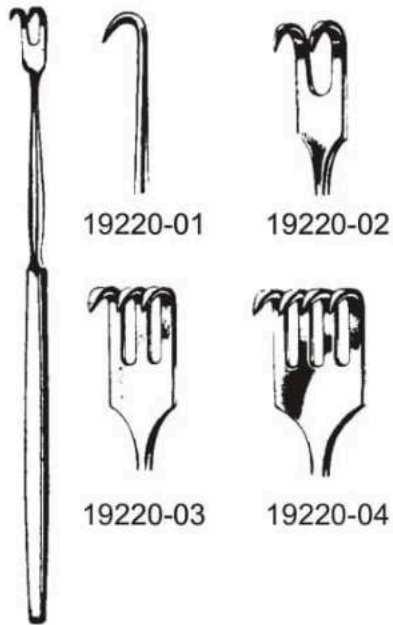

REDA
16 cm, 6 1/4"

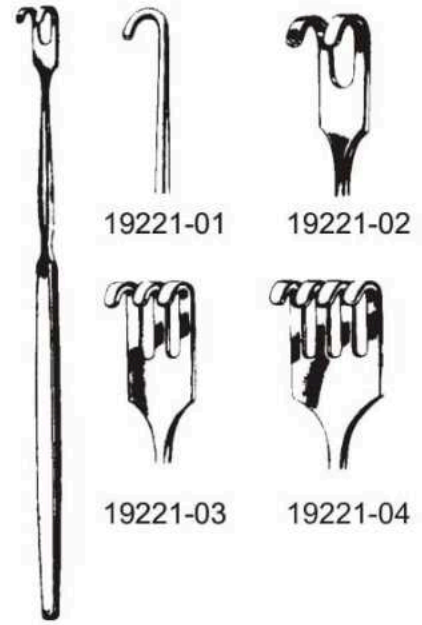

REDA
16 cm, 6 1/4"

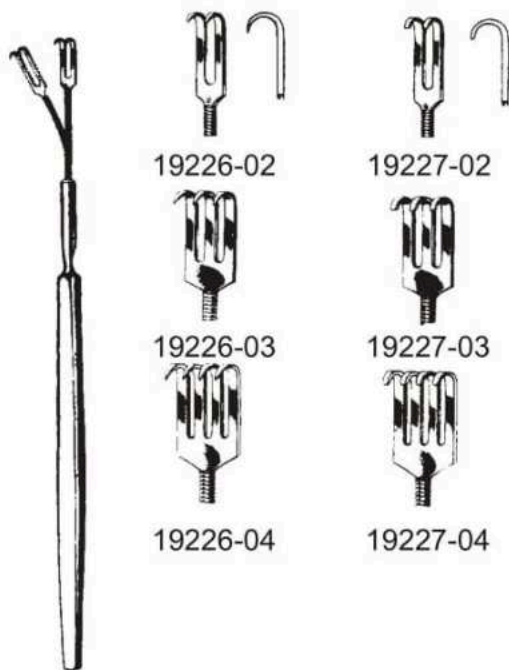

REDA, flexibel
16 cm, 6 1/4"



KLAPP
17,5 cm, 6.9"

Wundhaken
Retractors
Separadores
Divaricatori



DESMARRES
19230-00 16 cm, 6¹/₄"

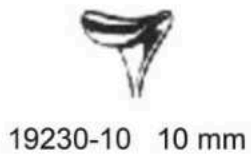

19230-10 10 mm



19230-16 16 mm



19230-12 12 mm



19230-18 18 mm



19230-14 14 mm



DESMARRES
19234-00 14 cm, 5¹/₂"

8 mm

10 mm



KASDAN
19237-16 16 cm, 6¹/₄"



VOLKMANN
11,5 cm, 4¹/₂"



19270-02



19271-02



19270-03



19271-03



19270-04



19271-04



19270-06



19271-06

Wundhaken
Retractors
Separadores
Divaricatori



MEYERDING
18 cm, 7"



19302-01 18x7 mm

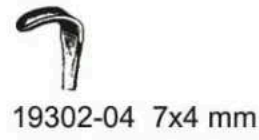

19302-04 7x4 mm



19302-02 16x5 mm



19302-05 10x3 mm



19302-03 7x4 mm



19302-06 10x4 mm



STRANDELL-STILLE
17 cm, 6³/₄"



19307-01



19307-02

Wundsperrer
Retractors
Separadores
Divaricatori

3x4



spitz
sharp
agudo
acuto

stumpf
blunt
romo
smusso

FINSEN
7 cm, 2³/₄"

19610-07

19611-07

4x4



spitz
sharp
agudo
acuto

stumpf
blunt
romo
smusso

ALM

7 cm, 2³/₄"
10 cm, 4"

19620-07
19620-10

19621-07
19621-10

3x3



spitz
sharp
agudo
acuto

stumpf
blunt
romo
smusso

JANSEN
10 cm, 4"

19630-10

19631-10

4x4



spitz
sharp
agudo
acuto

stumpf
blunt
romo
smusso

HOLZHEIMER

19634-10 10 cm, 4" 19635-10

Wundsperrer
Retractors
Separadores
Divaricatori

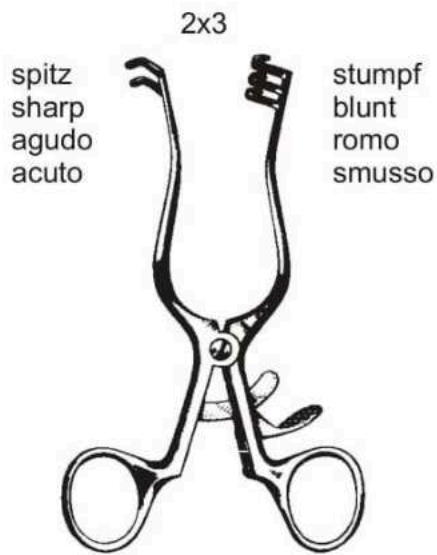

19650-10 WEITLANER 11,5 cm, 4 1/2" 19651-10

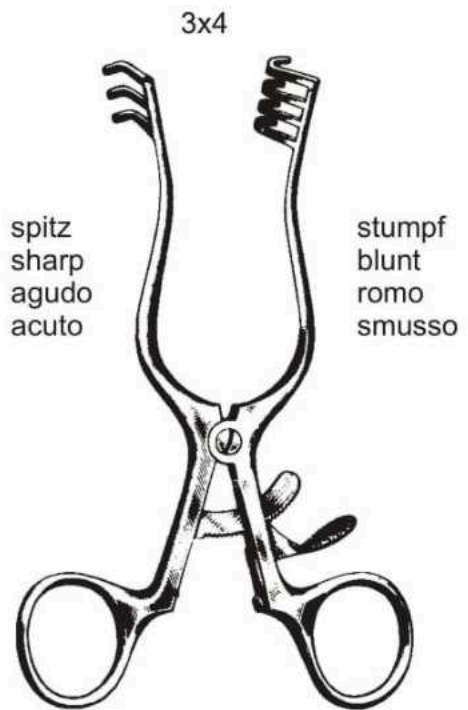

19670-14 WEITLANER 14 cm, 5 1/2" 19671-14

Endo Dissektoren
Endo dissectors
Disectores
Dissettori



24 cm, 9 1/2"



19741-01 LANGENBECK, 5,0 mm
19741-02 LANGENBECK, 7,0 mm
19741-03 LANGENBECK, 10,0 mm



19741-04 LANGENBECK, 5,0 mm
19741-05 LANGENBECK, 7,0 mm
19741-06 LANGENBECK, 10,0 mm



19741-07 LANGENBECK, 12,5 mm



19741-08 LANGENBECK-COTTLE 7,0 mm



19741-09 LANGENBECK-COTTLE, 7,0 mm



19741-10 LANGENBECK
konkav, concave, concavo, concavo



19741-11 Mini-LANGENBECK



Nervenhaken / nerve hook
gancho para nervios / uncino p. nervi

19741-12 links / left / izquierda / sinistra
19741-13 rechts / right / derecha / destra

Wundhaken für plastische Chirurgie
 Retractors for plastic surgery
 Separadores para cirugía plástica
 Divaricatore per chirurgia plastica



mit Kaltlicht + Absaugung
 with cold light + aspiration
 con luz fria + aspiracion
 con luce fredda + aspirazione

FERRIERA

- 19960-01 80 mm x 16 mm
- 19960-02 100 mm x 25 mm
- 19960-03 120 mm x 25 mm
- 19960-04 120 mm x 30 mm
- 19960-05 150 mm x 25 mm
- 19960-06 150 mm x 30 mm
- 19960-07 150 mm x 36 mm



mit Kaltlicht + Absaugung
 with cold light + aspiration
 con luz fria + aspiracion
 con luce fredda + aspirazione

TEBBETTS

- 19980-00 180 mm x 25 mm
- 19980-01 80 mm x 16 mm
- 19980-02 100 mm x 25 mm
- 19980-03 120 mm x 25 mm
- 19980-04 120 mm x 30 mm
- 19980-05 150 mm x 25 mm
- 19980-06 150 mm x 30 mm

Wundhaken für plastische Chirurgie
 Retractors for plastic surgery
 Separadores para cirugía plástica
 Divaricatore per chirurgia plastica



180 x 25 mm

passend für 10 mm Optik
 for 10 mm scope
 para óptica de 10 mm
 per ottica 10 mm

Ø 10 mm

19999-10



180 x 25 mm

passend für 4 mm Optik
 for 4 mm scope
 para óptica de 4 mm
 per ottica 4 mm

Ø 4 mm

19999-40



BIGGS

19999-30	30 mm
19999-50	50 mm
19999-30 CL	30 mm
19999-50 CL	50 mm

CL = mit Kaltlicht + Absaugung
 with cold light + aspiration
 con luz fria + aspiracion
 con luce fredda + aspirazione

Spatel
Spatula
Espatula
Spatola

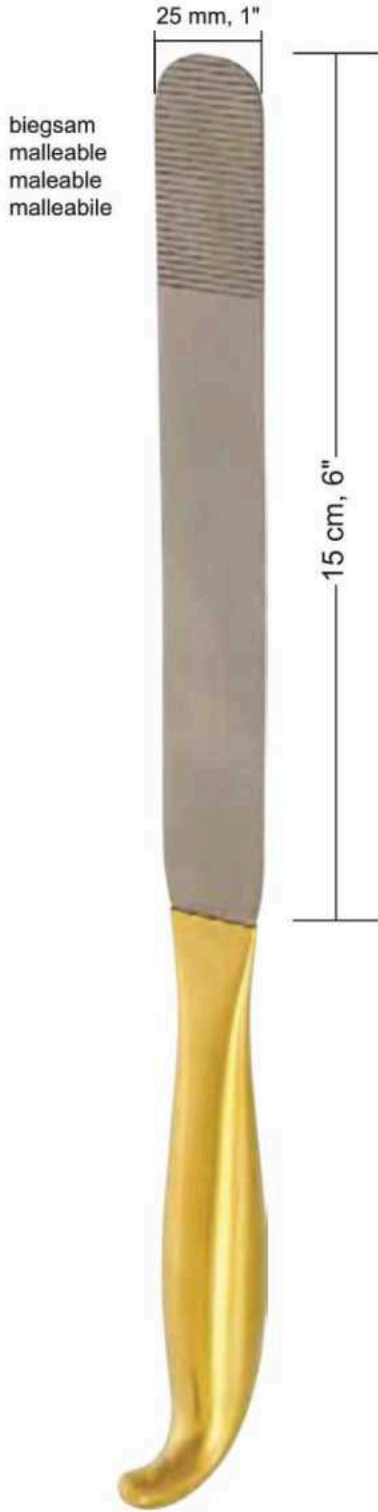

biegsam
malleable
maleable
malleabile



19992-31
31,5 cm, 12 1/2"

BREAST

19970-23	23,0 cm, 9"	34 x 100 cm, 20 x 60 cm
19970-24	24,0 cm, 9 1/2"	38 x 70 cm, 22 x 55 cm
19970-01	31,5 cm, 12 1/2"	38 x 70 cm, 20 x 55 cm

Brustdissektoren
Breast Dissectors
Separadores mamarios
Separatori mammari



AGRIS-DINGMAN
19999-00
36 cm, 14"

MacCOLLUM-DINGMAN
19999-01 41 cm, 16"
19999-31 31,5 cm, 12¹/₂"

TEBBETTS
19999-02
33 cm, 13"

TEBBETTS
19999-03
33 cm, 13"

REYNOLDS
(Transauxillary)
19999-05
40 cm, 16"

Brustdissektoren
Breast Dissectors
Separadores mamarios
Separatori mammari



SILVERSTEIN
19999-04
35,5 cm, 14"

LOCKWOOD
19999-06
38 cm, 15"

19989-22 22,0 cm, 8³/₄"
19989-29 29,5 cm, 9¹/₂"

19999-22 22,0 cm, 8³/₄"
19999-29 29,5 cm, 9¹/₂"

Wundhaken für plastische Chirurgie
Retractors for plastic surgery
Separadores para cirugía plástica
Divaricatore per chirurgia plastica



YANCOSKIE
19990-18
18 cm, 7"



YANCOSKIE
19991-18
18 cm, 7"

Wundhaken für plastische Chirurgie
 Retractors for plastic surgery
 Separadores para cirugía plástica
 Divaricatore per chirurgia plastica

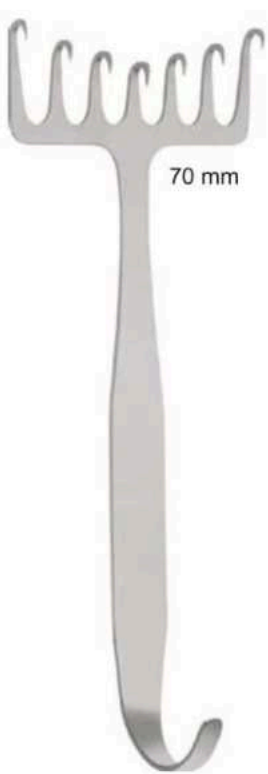

CORONAL
 19980-18
 18 cm, 7"



FREEMAN
 18 cm, 7"



19995-22
 22 mm



19995-38
 38 mm



FREEMAN
 19996-18
 18 cm, 7"

3 Finger
 3 prongs
 3 dientes
 3 rebbi



5 Finger
 5 prongs
 5 dientes
 5 rebbi

19998-03 11 cm, 4 1/2" 19998-05



GORNEY
 19996-04
 7,5 cm, 3"



FREEMAN
 19997-09
 10 cm, 4"

rechts
 right
 derecho
 destro

19998-01



MILLARD

links
 left
 izquierda
 sinistra

19998-02

rechts
 right
 derecho
 destro

19998-11



MILLARD

links
 left
 izquierda
 sinistra

19998-12

Nervenhaken, Durahaken
Nerve Hooks, Dura Hooks
Ganchos para nervios y para duramadre
Unicini per nervi e per dura-madre



CRILE
41054-20
20 cm, 8"

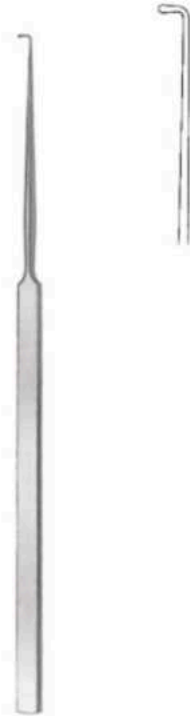

CUSHING
41056-18
18 cm, 7"



CUSHING
41058-18
18 cm, 7"



scharf
sharp
agudo
acuto

ADSON
41068-20
20 cm, 8"



stumpf
blunt
romo
smusso

ADSON
41069-20
20 cm, 8"

Feine Wundhaken
 Retractors
 Separadores
 Divaricatori



spitz
 sharp
 agudo
 acuti

O'CONNOR
 43370-12
 12 cm, 4³/₄"



spitz
 sharp
 agudo
 acuti

WIENER
 43372-13
 13 cm, 5¹/₈"



stumpf
 blunt
 romo
 smussi

WIENER
 43373-13
 13 cm, 5¹/₈"

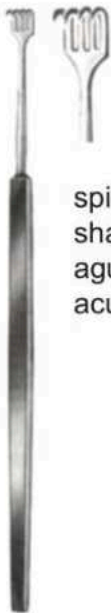

spitz
 sharp
 agudo
 acuti

ROLLET
 43376-13
 13,5 cm, 5¹/₄"

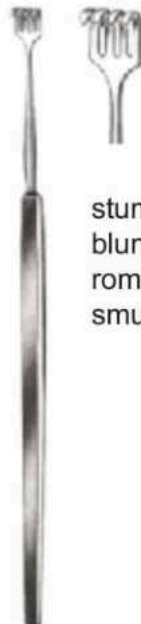

stumpf
 blunt
 romo
 smussi

KNAPP
 43377-13
 13 cm, 5¹/₈"



spitz
 sharp
 agudo
 acuti

MILLER
 43378-13
 13 cm, 5¹/₈"

Nasenhaken
Nasal retractors
Separadores nasales
Retrattori nasali



CONVERSE
47538-01 9 cm, 3 1/2" 18 x 9,5 mm
47538-02 9 cm, 3 1/2" 28 x 12,5 mm
47538-03 9 cm, 3 1/2" 41 x 13,5 mm
47538-04 9 cm, 3 1/2" 53 x 13,5 mm



COTTLE
47540-16
16 cm, 6 1/4"



9 x 45 mm

MALINIAC
47550-11CL
10 cm, 4"



9 x 45 mm

MALINIAC
47550-11
10 cm, 4"



AUFRICHT
47551-16
16 cm, 6 1/4"



AUFRICHT
47551-16CL
16 cm, 6 1/4"



MASING-NEIVERT
47552-16
16 cm, 6 1/4"

10 x 12 mm



COTTLE
47553-15
15 cm, 6"

Hauthäkchen, Nasenhaken
 Skin hook, Nasal retractors
 Gancho para piel, Separadores nasales
 Uncino per pelle, Retrattori nasali



COTTLE
 14,5 cm, 5³/₄"

3 x 11 mm



KILNER
 47555-08 8 cm, 3¹/₈"



FOMON
 47556-16 16 cm, 6¹/₄"



FOMON
 47557-17 17 cm, 6³/₄"



FREER
 47558-15 15 cm, 6"



COTTLE-NEIVERT
 47559-20 20 cm, 8"

Feine Wundhaken
Retractors
Separadores
Divaricatori

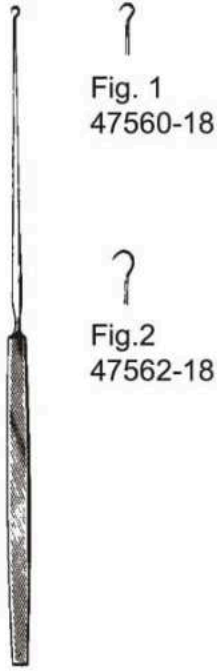

GILLIES
18 cm, 7"



LANGE
47563-22 23 cm, 9"



COTTLE
47564-16 16 cm, 6 1/4"



CONVERSE
47566-12 12 cm, 4 3/4"

7,5 mm



MARTINEZ-KILNER
47567-11 11,5 cm, 4 1/2"

8 mm



COTTLE
47568-08

Trachealhaken
Trachea Hooks
Ganchos para traqueotomía
Ganci per tracheotomia



JACKSON
55116-15
15 cm, 6"



JACKSON
55117-17
17 cm, 6³/₄"



NEWS
55120-15
15 cm, 6"

Nadelhalter
Needle Holders
Porta-agujas
Portaghi



DERF
25110-12 12 cm, 4³/₄" 25114-12 TC



WEBSTER
25128-13 13 cm, 5¹/₈"
25129-13 TC 13 cm, 5¹/₈"



HALSEY
25130-13 13 cm, 5¹/₈" 25140-13
25134-13 TC 13 cm, 5¹/₈" 25144-13 TC

Nadelhalter
Needle Holders
Porta-agujas
Portaghi



BAUMGARTNER

25150-12	12,5 cm, 5"	25154-12 TC
25150-14	14,0 cm, 5½"	25154-14 TC



CRILE-WOOD

25160-15	15 cm, 6"	25164-15 TC
25160-18	18 cm, 7"	25164-18 TC
	20 cm, 8"	25164-20 TC
	23 cm, 9"	25164-23 TC



MAYO-HEGAR

25180-12	12 cm, 4¾"	25184-12 TC
25180-14	14 cm, 5½"	25184-14 TC
25180-16	16 cm, 6¼"	25184-16 TC
25180-18	18 cm, 7"	25184-18 TC
25180-20	20 cm, 8"	25184-20 TC



DeBAKEY

25214-16 TC	16 cm, 6¼"
25214-18 TC	18 cm, 7"
25214-20 TC	20 cm, 8"
25214-23 TC	23 cm, 9"

Nadelhalter
Needle Holder
Porta-agujas
Portaghi



- | 1 mm | RYDER | 2 mm |
|------------|----------------------------------------|-------------|
| 25224-13TC | 13 cm, 5 ¹ / ₈ " | 25225-13 TC |
| 25224-15TC | 15 cm, 6" | 25225-15 TC |
| 25224-16TC | 16 cm, 6 ¹ / ₄ " | 25225-16 TC |
| 25224-18TC | 18 cm, 7" | 25225-18 TC |
| 25224-20TC | 20 cm, 8" | 25225-20 TC |



- | MICROVASCULAR | |
|---------------|-----------|
| 25230-18TC | 18 cm, 7" |
| 25230-20TC | 20 cm, 8" |



- | BABY OLSEN-HEGAR | | |
|------------------|----------------------------------------|------------|
| 25405-12 | 12 cm, 4 ³ / ₄ " | 25406-12 |
| 25408-12TC | 12 cm, 4 ³ / ₄ " | 25407-12TC |



- | OLSEN-HEGAR | | |
|-------------|----------------------------------------|------------|
| 25410-14 | 14 cm, 5 ¹ / ₂ " | 25414-14TC |
| 25410-17 | 17 cm, 6 ³ / ₄ " | 25414-17TC |
| | 18 cm, 7" | 25414-18TC |

Nadelhalter
Needle Holders
Porta-agujas
Portaghi



GILLIES

25434-11TC	11 cm, 4 ³ / ₈ "
25434-13TC	13 cm, 5 ¹ / ₈ "
25434-16TC	16 cm, 6 ¹ / ₄ "

Mikro-Nadelhalter
Micro Needle Holders
Micro-porta-agujas
Micro portaghi

ohne Sperre
without lock
sin cremallera
senza cremagliera

mit Sperre
with lock
con cremallera
con cremagliera



11,5 cm, 4 1/2"
13,0 cm, 5 1/8"
14,0 cm, 5 1/2"
18,0 cm, 7"
21,0 cm, 8 1/4"
23,0 cm, 9"



25660-12
25660-13
25660-14
25700-18

25661-12
25661-13
25661-14
25701-18

25720-12
25720-13
25720-14
25730-18
25730-21
25730-23

25731-12
25731-13
25731-14
25731-18
25731-21
25731-23

mit diamantiertem Maul
with diamond jaw
con boca de diamante
con morso diamantato

11,5 cm, 4 1/2"
13,0 cm, 5 1/8"
14,0 cm, 5 1/2"
18,0 cm, 7"
21,0 cm, 8 1/4"
23,0 cm, 9"

25720-12D
25720-13D
25720-14D
25730-18D
25730-21D
25730-23D

25671-12D
25671-13D
25671-14D
25731-18D
25731-21D
25731-23D

T= Titan, titanium, titanio, titanio



15,0 cm, 6"
18,0 cm, 7"
21,0 cm, 8 1/4"

93250-15T
93250-18T
93250-21T

93251-15T
93251-18T
93251-21T

93260-15T
93260-18T
93260-21T

93261-15T
93261-18T
93261-21T

BARRAQUER

Mikro-Nadelhalter mit Sperre
 Micro Needle Holders, with lock
 Micro-porta-agujas con cremallera
 Micro portaghi, con cremagliera



14,0 cm, 5 1/2"
 18,0 cm, 7"
 21,5 cm, 8 1/2"
 23,0 cm, 9"

25670-14
 25670-18
 25670-21

25671-14
 25671-18

25672-14
 25672-18
 25672-21
 25672-23

25673-14
 25673-18

mit TC 1,4 mm
 with TC jaw 1,4 mm
 con TC 1,4 mm
 con morso in TC 1,4 mm

14,0 cm, 5 1/2"
 18,0 cm, 7"
 21,5 cm, 8 1/2"
 23,0 cm, 9"

25674-14
 25674-18
 25674-21

25675-14
 25675-18

25676-14
 25668-18
 25668-21
 25668-23

25677-14
 25691-18

mit diamantiertem Maul 0,8 mm
 with diamond jaw 0,8 mm
 con boca de diamante 0,8 mm
 con morso diamantato 0,8 mm

14,0 cm, 5 1/2"
 18,0 cm, 7"
 21,5 cm, 8 1/2"
 23,0 cm, 9"

25672-14D
 25672-18D
 25672-21D
 25672-23D

25673-14D
 25673-18D

T= Titan, titanium, titanio, titanio
 Maul/jaw/boca/morso 0,4mm

14,0 cm, 5 1/2"
 18,0 cm, 7"
 21,5 cm, 8 1/2"

25672-14T
 25672-18T
 25672-21T

25673-14T
 25673-18T
 25673-21T

CASTROVIEJO

Drahtzangen
Wire Twisting Forceps
Pinza para torcer hilos
Pinza torcifili



MAYO-HABERISSER



34554-15 TC 15 cm, 6" 34555-15 TC



34554-18 TC 18 cm, 7" 34555-18 TC



34554-20 TC 20 cm, 8" 34555-20 TC



BERRY

34556-18TC 18 cm, 7"

Hohlmeißelzange
 Bone Rongeurs
 Pinzas-gubias
 Pinze sgorbie

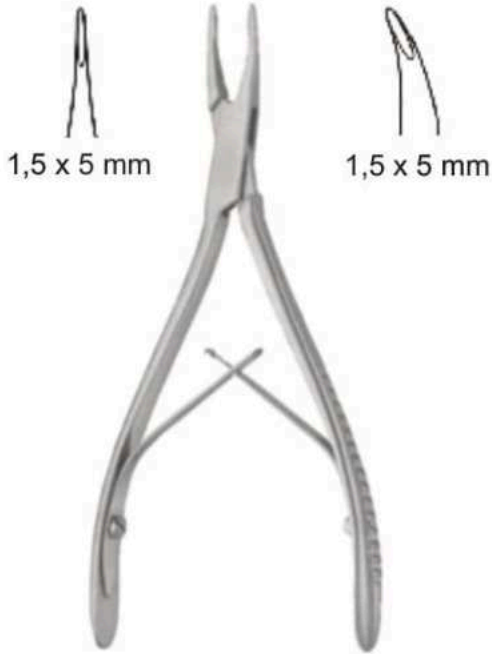

MICRO FRIEDMANN
 33100-01 14,5 cm, 5³/₄" 33100-02



FRIEDMANN MINI
 33101-12 12 cm, 4³/₄"



FRIEDMANN
 33101-14 14 cm, 5¹/₂"



BEYER
 33201-18 18 cm, 7"

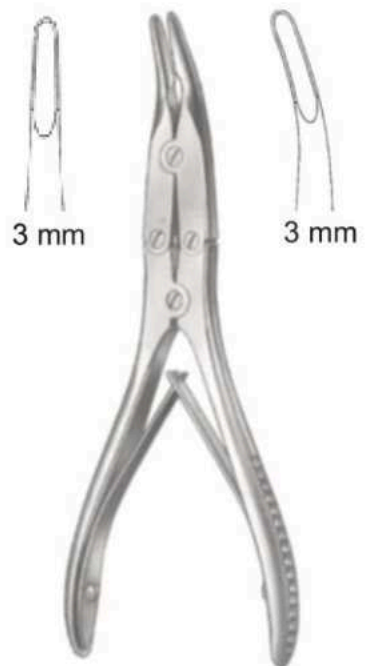

BÖHLER
 33211-15 15 cm, 6" 33213-15

Knochensplitterzangen
Bone Cutting Forceps
Pinzas cortantes para huesos
Cesoie per ossa



BÖHLER
33280-15 15 cm, 6"



BÖHLER
33281-15 15 cm, 6"



COTTLE-KAZANJIAN
33282-19 19 cm, 7 1/2"



MC INDOE
33283-17 17 cm, 6 3/4"

Hämmer
Bone Mallets
Martillos
Martelli

Ø 25 mm



GERZOG
33686-25
18 cm, 7" 250g

Ø 25 mm



33694-01 18,5 cm, 7¹/₄", 135 g
33694-03 Ersatzbacken
Nylon Caps
Tapas de repuesto
Placche di ricambio

Ø 25 mm



33694-02 18,5 cm, 7¹/₄"
mit Nylonbacke
with nylon tap
con tapa de nylon
con placca di nylon

Ø 20 mm



MEAD
33693-32
17 cm, 6³/₄" 320 g

Ø 22 mm



PARTSCH
33698-98
18 cm, 7" 199 g



QUISLING
33696-75
17 cm, 6³/₄"

Ø 30 mm



COTTLE
33700-05
18 cm, 7" 240 g

Elevatoren, Raspatoren
Elevators, Raspatories
Elevadores, Legras
Elevatori, Periostotomi



LANGENBECK
20 cm, 8"
33711-20 8 mm
33711-21 10 mm



4 mm

WILLIGER
16 cm, 6 1/4"
33711-16



6,5 mm

WILLIGER
16 cm, 6 1/4"
33712-16



5,5 mm

WILLIGER
33713-17
16 cm, 6 1/4"



4 mm

JOSEPH
33718-16
16 cm, 6 1/4"



4 mm

FOMON
33719-17
16 cm, 6 1/4"

Elevatoren, Raspatoren
Elevators, Raspatories
Elevadores, Legras
Elevatori, Periostotomi

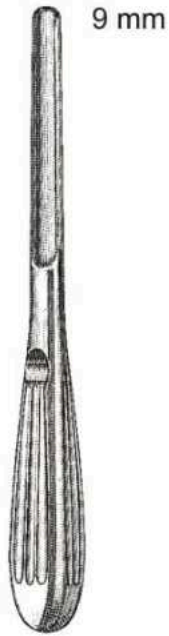

BOIES
33720-19
19 cm, 7½"



GORNEY
33720-21
21 cm, 8¼"

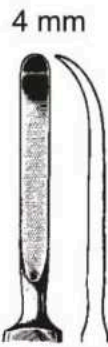

47410-04



McKENTY
15 cm, 6"



47410-05



JOSEPH
47411-16
16 cm, 6¼"



MASING
47414-21
22 cm, 8¾"



FREER
47415-18
18 cm, 7"



FREER
47417-19
19 cm, 7½"



FREER
47419-19
19 cm, 7½"

Elevatoren, Raspatoren
Elevators, Raspatories
Elevadores, Legras
Elevatori, Periostotomi



KILLIAN
47420-01
18,5 cm, 7¹/₄"



PIERCE
47420-02
21 cm, 8¹/₄"



SINUS
47420-03
18 cm, 7"



PENNINGTON
47420-04
21 cm, 8¹/₄"



McKENTY
47420-20
22 cm, 8³/₄"



HOWARTH
47421-21
21,5 cm, 8¹/₂"



COTTLE
47421-23
23 cm, 9"



COTTLE JOSEPH
47422-22
22 cm, 8³/₄"

Elevatoren, Raspatoren
 Elevators, Raspatories
 Elevadores, Legras
 Elevatori, Periostotomi



COTTLE
 47423-22 22 cm, 8³/₄"



COTTLE
 47424-16 16 cm, 6¹/₄"



COTTLE
 47425-19 19 cm, 7¹/₂"



KILLIAN
 47426-22 22 cm, 8³/₄"



HAJEK-BALLENGER
 47428-21 22 cm, 8³/₄"



BALLENGER
 47430-22 22 cm, 8³/₄"

Lippen- und Gaumenspaltinstrumente
Lip and Cleft Palate Instruments
Instrumentos para labios y fisura palatina
Strumenti per labbra e fessure del palato



Lippen- und Gaumenspaltinstrumente
Lip and Cleft Palate Instruments
Instrumentos para labios y fisura palatina
Strumenti per labbra e fessure del palato



BLAIR
49281-01
23 cm , 9"



BLAIR
49281-02
20 cm, 8"

Saugkanülen
Suction Tubes
Tubos de aspiracion
Cannula aspirante



ADSON
41290-21
20 cm, 8¹/₄"
Ø 4 mm



Arbeitslänge
working length
largo útil
lunghezza utile
75 mm

BARON
41299-03 3FR Ø 1,0 mm
41299-05 5FR Ø 1,6 mm
41299-07 7FR Ø 2,3 mm

Saugkanülen
Suction Tubes
Tubos de aspiracion
Cannula aspirante



FRAZIER/FERGUSSON
19 cm, 7 1/2"

Charr.

F.G.	Ø	30°	75°
6	2,0 mm	41295-06	41297-06
7	2,3 mm	41295-07	41297-07
8	2,7 mm	41295-08	41297-08
9	3,0 mm	41295-09	41297-09
10	3,3 mm	41295-10	41297-10
11	3,6 mm	41295-11	41297-11
12	4,0 mm	41295-12	41297-12

Saugkanülen
Suction Tubes
Tubos de aspiracion
Cannula aspirante



GUILLEN
47347-20
19 cm, 7 1/2"
Ø 4 mm

Nasenspekula
Nasal Speculum
Espéculos nasales
Specoli nasali



HARTMANN-HALLE
15 cm, 6"

28 mm

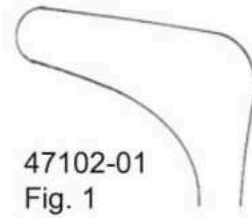

47102-01
Fig. 1

30 mm

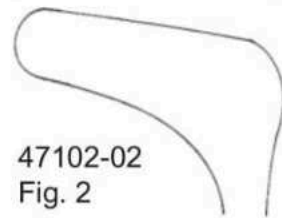

47102-02
Fig. 2

32 mm

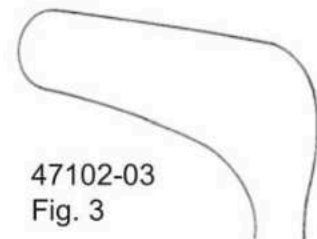

47102-03
Fig. 3

Nasenspekula
Nasal Speculum
Espéculos nasales
Specoli nasali



HARTMANN
16 cm, 6¹/₄"

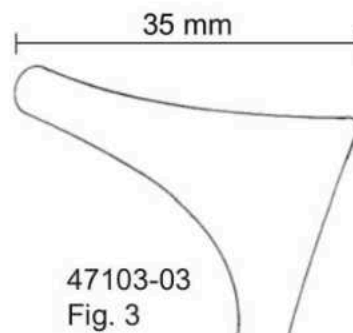
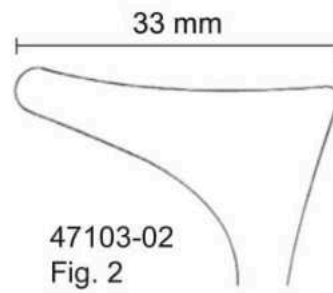
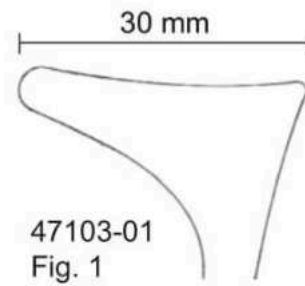

Nasenspekula
 Nasal Speculum
 Espéculos nasales
 Specoli nasali



Mod. WIEN
 14 cm, 5 1/2"

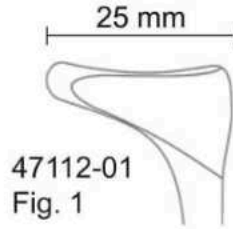

Baby, bebé, neonato

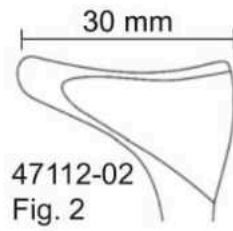

Kind, child, niño, bambino

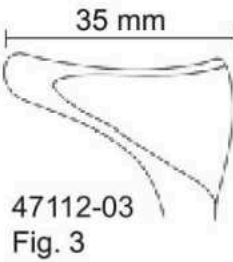

Erwachsene, Adult, adulto



TIECK-HALLE
 47116-13
 13,5 cm, 5 1/4"



REDA
 47118-13
 12,5 cm, 5"

Nasenspekula
Nasal Specula
Espéculos nasales
Specoli nasali

CL = mit Kaltlicht
with cold light
con luz fria
con luce fredda



KILLIAN
13 cm, 5 1/8"

35 mm

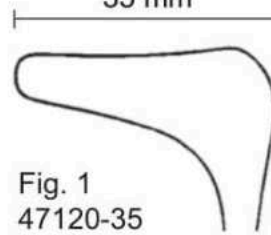

Fig. 1
47120-35
47120-35CL

50 mm

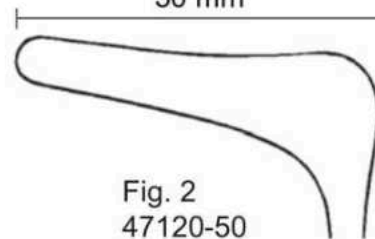

Fig. 2
47120-50
47120-50CL

75 mm

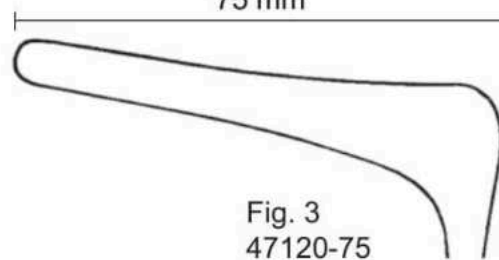

Fig. 3
47120-75
47120-75CL

90 mm

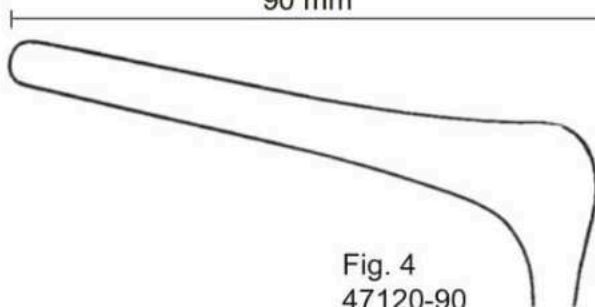

Fig. 4
47120-90
47120-90CL

Nasenspekula
Nasal Specula
Espéculos nasales
Specoli nasali



KILLIAN
13 cm, 5 1/8"

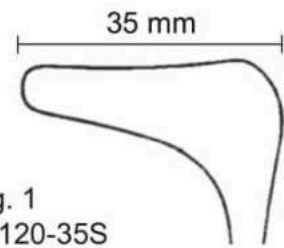

Fig. 1
47120-35S

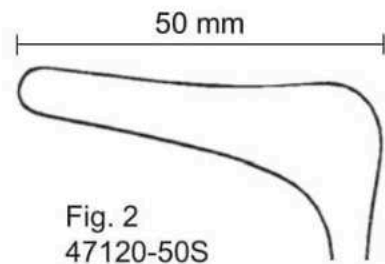

Fig. 2
47120-50S

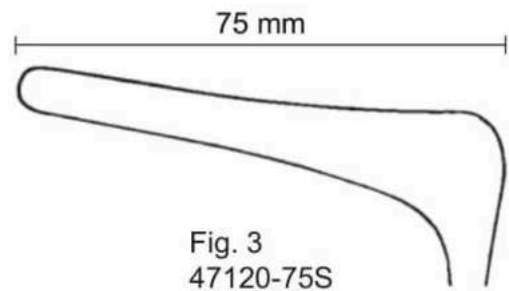

Fig. 3
47120-75S

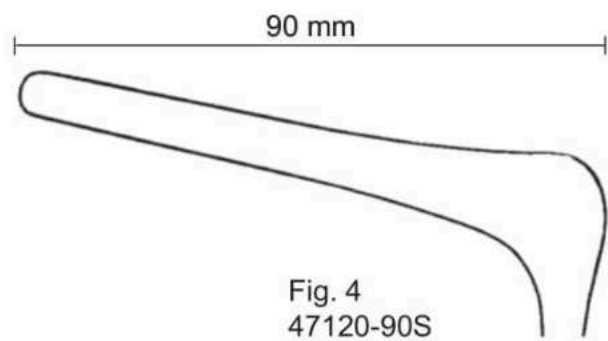

Fig. 4
47120-90S

Nasenspekula
Nasal Speculum
Espéculos nasales
Specoli nasali

35 mm



Fig. 1
47124-35
47124-35CL

50 mm



Fig. 2
47124-50
47124-50CL

75 mm

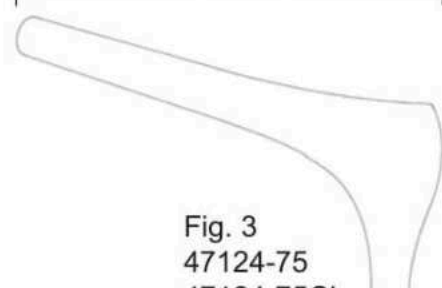

Fig. 3
47124-75
47124-75CL

90 mm

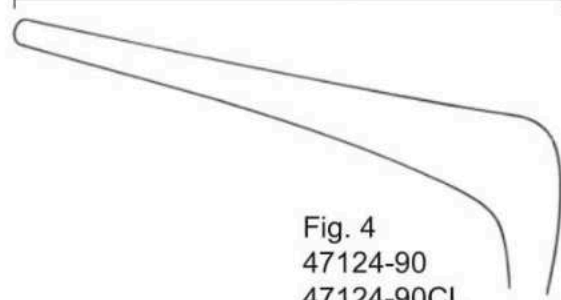

Fig. 4
47124-90
47124-90CL

CL = mit Kaltlicht
with cold light
con luz fria
con luce fredda



COTTLE
14 cm, 5 1/2"

Nasenspekula
Nasal Speculum
Espéculos nasales
Specoli nasali



COTTLE
14 cm, 5 1/2"

35 mm

Fig. 1
47124-35S

50 mm

Fig. 2
47124-50S

75 mm

Fig. 3
47124-75S

90 mm

Fig. 4
47124-90S

Nasentamponzange, Polypenzange
Nasal Tampon Forceps, Ear Polypus Forceps
Pinza para taponamiento, Pinzas para pólipos
Pinze per medicature, Pinze per polipi



WESTMACOTT
47158-20 20 cm, 8"



LUBET-BARBON
47159-20 20 cm, 8"



HARTMANN
47161-16 16 cm, 6 1/4"



HARTMANN
47161-20 20 cm, 8"

Polypenzangen, Septumzangen
Nasal Polypus and Septum Forceps
Pinzas para pólipos y para el tabique nasal
Pinze per polipi, Pinze per il setto nasale



HEYMANN-KNIGHT
47169-18
18 cm, 7"



KNIGHT
47185-18
18 cm, 7"

Septumzangen
Septum Forceps
Pinzas para el tabique nasal
Pinze per il setto nasale



BRUENINGS
19 cm, 7 1/2"

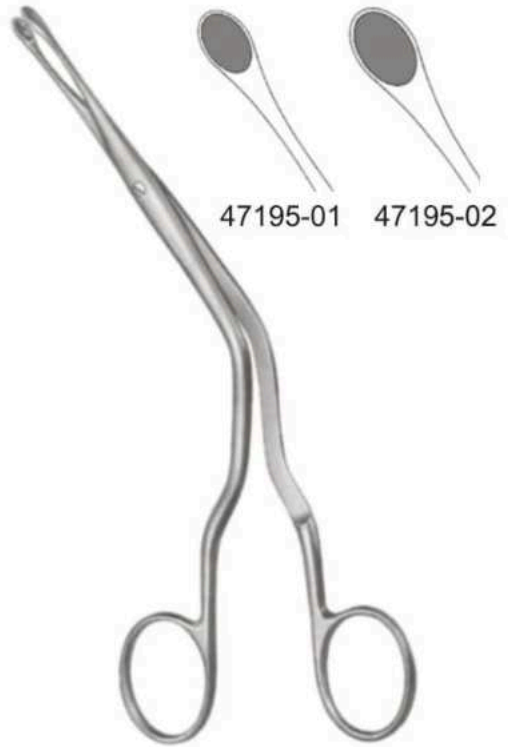

LUC
19 cm, 7 1/2"





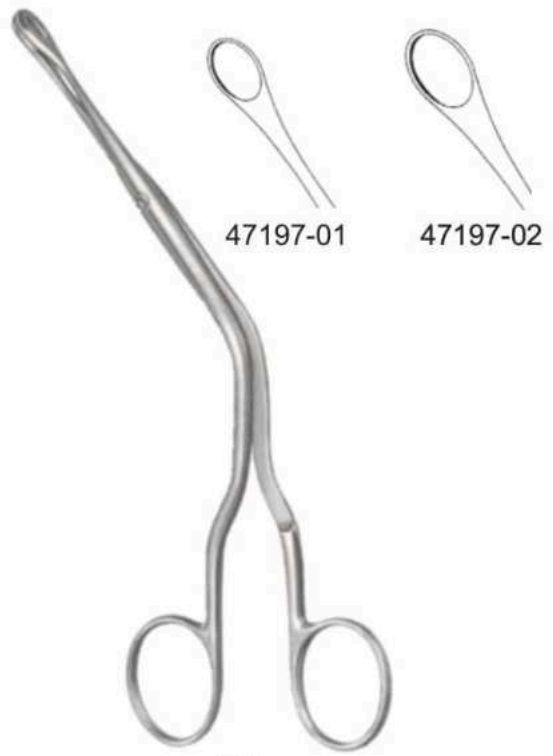







CRAIG
47192-16 18 cm, 7"



LUC
47197-02 19 cm, 7 1/2"

Scharfe Nasenzange
 Nasal Cutting Forceps
 Pinzas cortantes nasales
 Pinze taglianti nasali

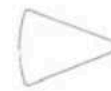

					
	Fig.1	Fig. 2	Fig.3	Fig.4	Fig. 5
	47223-01 3,0 mm	47223-02 3,6 mm	47223-03 4,2 mm	47223-04 4,8 mm	47223-05 5,8 mm
	47224-01 3,0 mm	47224-02 3,6 mm	47224-03 4,2 mm	47224-04 4,8 mm	47224-05 5,8 mm
	47225-01 3,0 mm	47225-02 3,6 mm	47225-03 4,2 mm	47225-04 4,8 mm	
	47226-01 2,0 mm	47226-02 2,5 mm	47226-03 3,0 mm	durchschneidend through cutting cortantes taglianti	
	47227-01 2,0 mm	47227-02 2,5 mm	47227-03 3,0 mm		

Scharfe Nasenzangen
Nasal Cutting Forceps
Pinzas cortantes nasales
Pinze taglienti nasali

47237-01
3 mm

47237-02
3,5 mm



47239-01

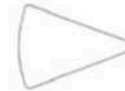

47239-02



MYLES



SCHMEDEN

120 mm



TAKAHASHI

4 mm



47242-00

4 mm



47242-01

Septumzange, Nasenscheren
Septum Forcep, Nasal Cutting Scissors
Pinza para el tabique nasal, Tijeras nasales
Pinza per setto nasale, Forbici nasali



RUBIN
47251-21
21 cm, 8¹/₄"



CAPLAN
47256-20
20 cm, 8"



GORNEY
49257-20 TC
20 cm, 8"

Septumzangen
Septum Forceps
Pinzas para el tabique nasal
Pinze per il setto nasale



MIDDLETON-JANSEN
47323-19
19 cm, 7 1/2"



MIDDLETON-JANSEN
47325-19
19 cm, 7 1/2"

Rhinoplastikmesser
 Rhinoplasty knives
 Cuchillos nasales
 bisturi nasale



JOSEPH
 16 cm, 6 1/4"



47370-16 47371-16
 stumpf, blunt,
 romo, smussi



47372-16 47373-16
 spitz, pointed,
 agudo, acuti



FREER
 47374 - 16
 16,5 cm, 6 1/2"



JOSEPH
 47375 - 16
 16 cm, 6 1/4"

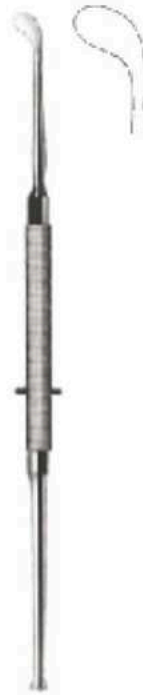

FREER
 47375 - 19
 19 cm, 7 1/2"



JOSEPH
 47376 - 16
 16 cm, 6 1/4"

Rhinoplastikmesser
Rhinoplasty knives
Cuchillos nasales
bisturi nasale

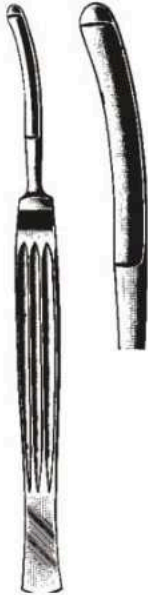

CONVERSE
47379 - 16
16 cm, 6 1/4"



COTTLE
47380-15
15 cm, 6"



COTTLE
47382-15
15 cm, 6"



JOSEPH
47384-15
15 cm, 6"



JOSEPH
47385-15
15 cm, 6"



47386-01
spitz
pointed
agudo
acuto

47386-02
stumpf
blunt
romo
smusso

REDA
19 cm 7 1/2"

Schwingmesser
Septum Swivel Knives
Cuchillos para el tabique nasal
Coltelli per setto



BALLENGER
47390-03 - 47392-05
20 cm, 8"

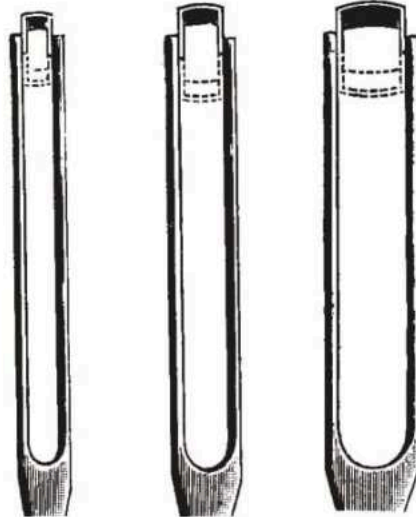

47390-03 3 mm
47390-04 4 mm
47390-05 5 mm

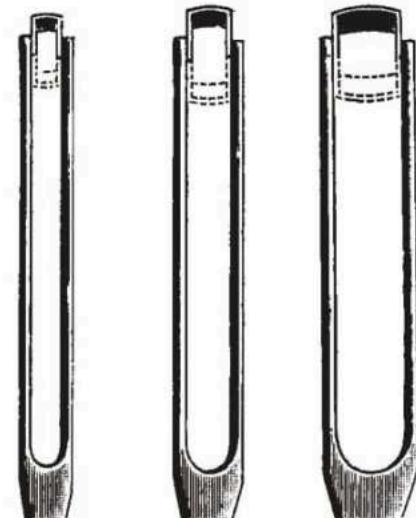

47392-03 3 mm
47392-04 4 mm
47392-05 5 mm

Osteotome, Septum Meißel
 Osteotomes, Rhinoplastic Chisels
 Osteotomo, Cinceles para la plástica nasal
 Osteotomi, Scalpelli per plastica nasale

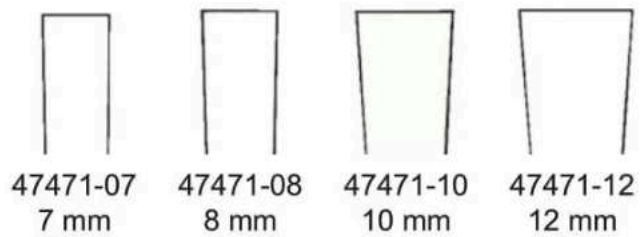
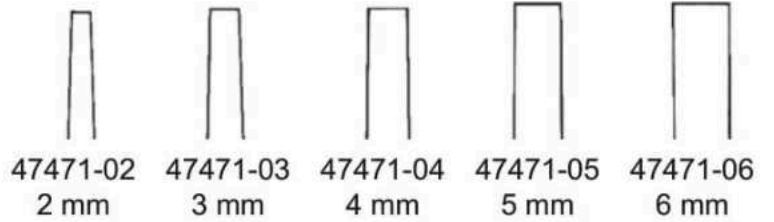
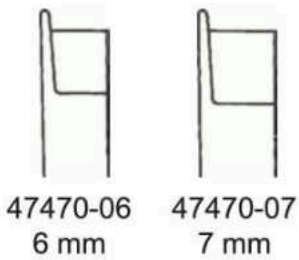
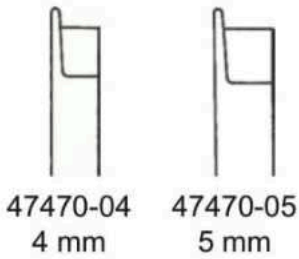

FOMON
 47470-04 - 47470-07
 17 cm, 6³/₄"

SHEEHAN
 47471-07 - 47471-12
 16 cm, 6¹/₄"

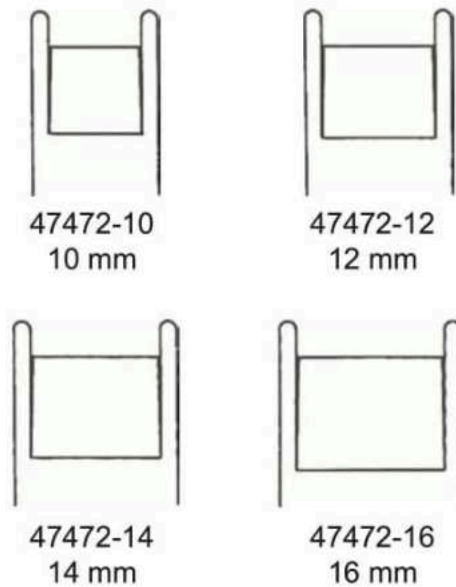

CINELLI
 47472-10 - 47472-16
 16 cm, 6¹/₄"

Septum Meißel
Rhinoplastic Chisels
Cinceles para la plástica nasal
Scalpelli per plastica nasale

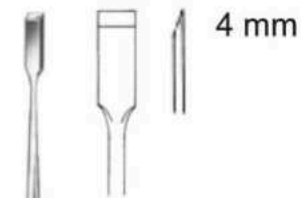

FREER
47450-04
15 cm, 6"

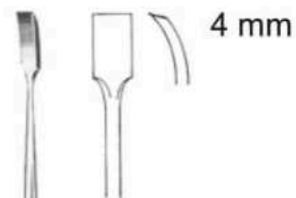

FREER
47451-04
15 cm, 6"

Septum Meißel, Osteotome
 Rhinoplastic Chisels, Osteotomes
 Cinceles para la plástica nasal, Osteotomos
 Scalpelli per plastica nasale, Osteotomi

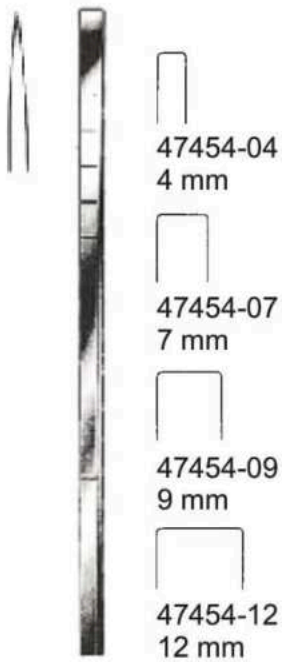

COTTLE
 18 cm, 7"



COTTLE
 47455-06
 18 cm, 7"

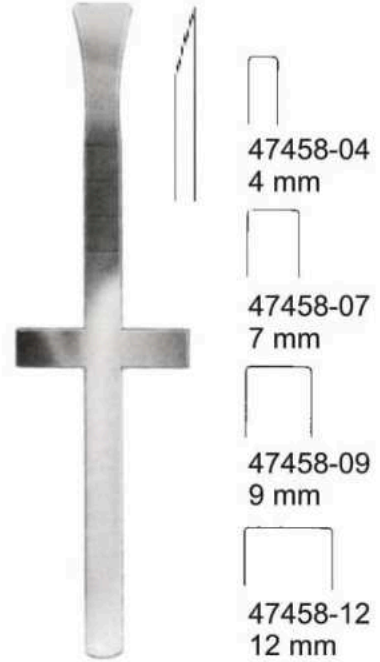

COTTLE
 18 cm, 7"

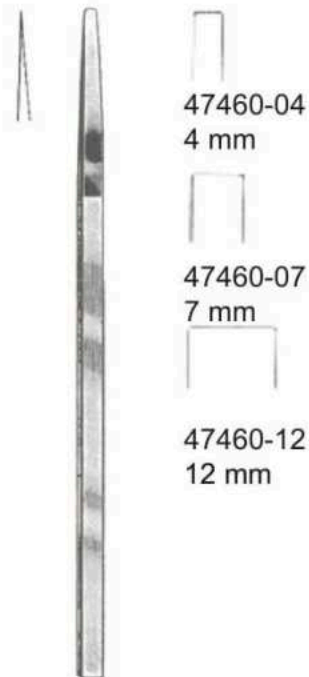

COTTLE
 18 cm, 7"

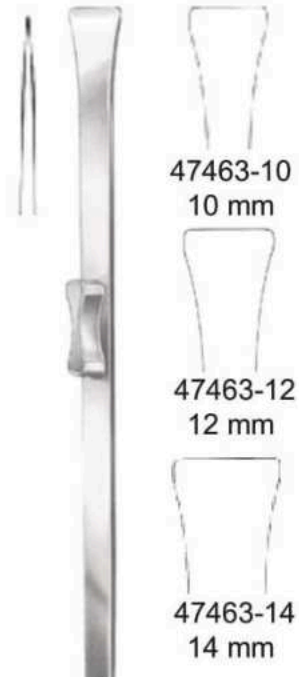

RUBIN
 18,5 cm, 7 1/4"

Osteotome, Septum Meißel
 Osteotomes, Rhinoplastic Chisels
 Osteotomo, Cinceles para la plástica nasal
 Osteotomi, Scalpelli per plastica nasale

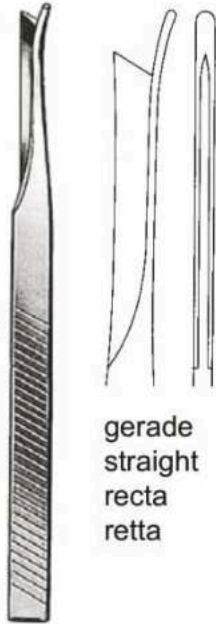

gerade
 straight
 recta
 retta

SILVER
 47473-01
 18 cm, 7"

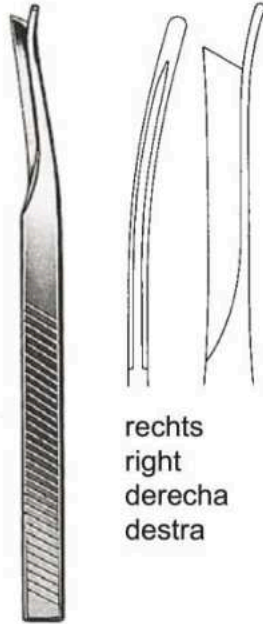

rechts
 right
 derecha
 destra

SILVER
 47473-02
 18 cm, 7"

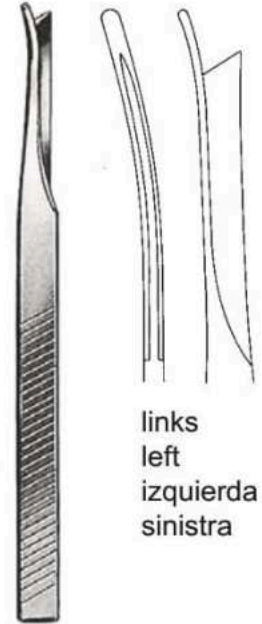

links
 left
 izquierda
 sinistra

SILVER
 47473-03
 18 cm, 7"

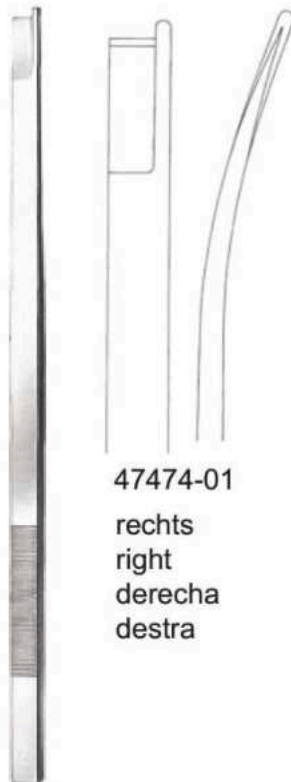

47474-01
 rechts
 right
 derecha
 destra

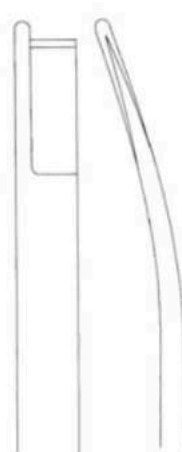

47474-02
 links
 left
 izquierda
 sinistra

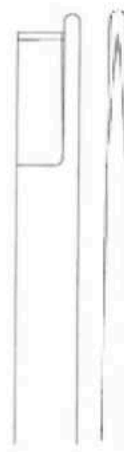

47474-03
 gerade
 straight
 recta
 retta

NEIVERT-ANDERSON
 20,5 cm, 8" 7 mm



KILLIAN
 47481-05 16 cm, 6 1/4"

Osteotome
Osteotomes
Osteotomo
Osteotomi

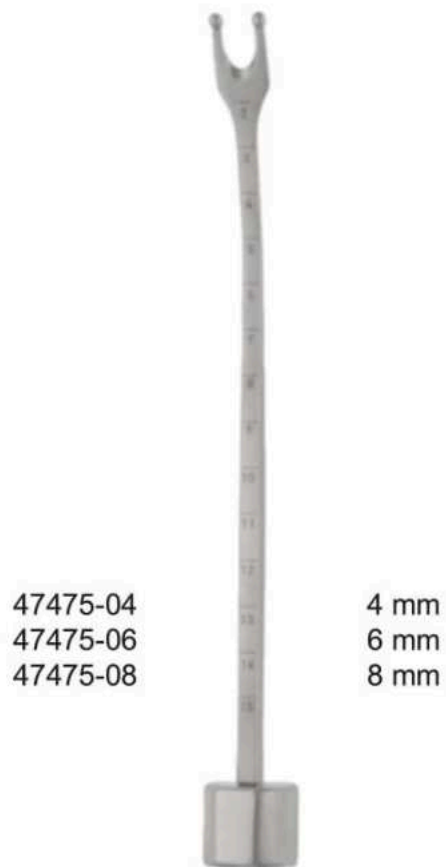

OBWEGESER
18,5 cm, 7¹/₄"

Septum Meißel, Osteotome, Hohlmeißel
 Rhinoplastic Chisels, Osteotomes, Gouges
 Cinceles para la plástica nasal, Osteotomos, Gubias
 Scalpelli per plastica nasale, Osteotomi, Sgorbie



KILLIAN-CLAUS
 47482-05
 17 cm, 6³/₄"



HAJEK mm
 47484-04 4
 47484-06 6
 47484-08 8
 16 cm, 6¹/₄"



WEST
 47486-16
 16 cm, 6¹/₄"



WEST
 47487-16
 16 cm, 6¹/₄"

6 mm



FREER
 47489-16
 16 cm, 6¹/₄"



MINI-LAMBOTTE

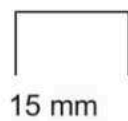
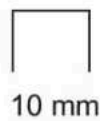
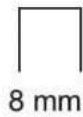
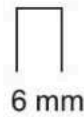
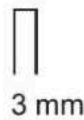
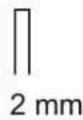

12,5 cm, 5"
 33654-02
 33654-03
 33654-04
 33654-05
 33654-06
 33654-08
 33654-10
 33654-12
 33654-15

mm
 2
 3
 4
 5
 6
 8
 10
 12
 15

17 cm, 6³/₄"
 33652-02
 33652-03
 33652-04
 33652-05
 33652-06
 33652-08
 33652-10
 33652-12
 33652-15

Knorpelquetscher
Cartilage crusher
Macha cadera
Tritacartilagine



COTTLE
47461-00 7,5 cm, 3"

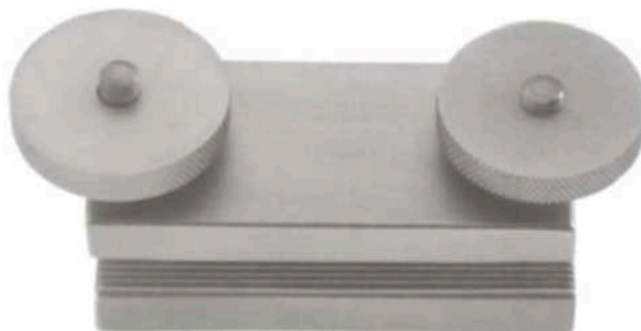

JOST
47462-00

Nasenraspeln
Nasal Rasps
Escofinas nasales
Raspa nasale



JOSEPH
47502-16 16 cm, 6 1/4"



MALTZ
47504-18 18 cm, 7"



47507-17

47507-18

WIENER
18 cm, 7"



diamantiert
with diamond coating
con boca de diamante
diamantata

PEET
47523-01 19 cm 7 1/2" 47523-02



GLABELLA
47524-01 21 cm, 8 1/4"



47525-20
fein, fine, fino, fina
20 Zähne
20 teeth
20 dientes
20 denti

47526-20
grob, coarse, gruesa, grossa
11 Zähne
11 teeth
11 dientes
11 denti

PARKES
47525-20 21 cm, 8 1/4"

Nasenraspeln
Nasal Rasps
Escofinas nasales
Raspa nasale



AUFRICHT
47511-21 21 cm, 8 1/4" 47513-21



JOSEPH (LEWIS)
47514-16 18 cm, 7" 47516-16

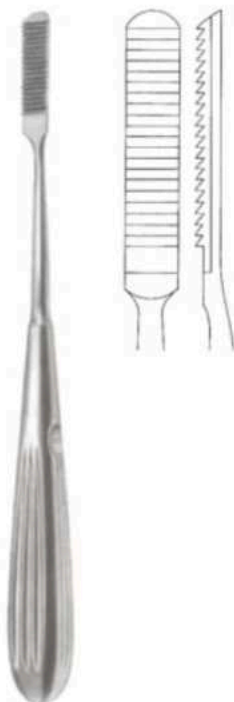

MALTZ (COTTLE)
47518-21 21 cm, 8 1/4"

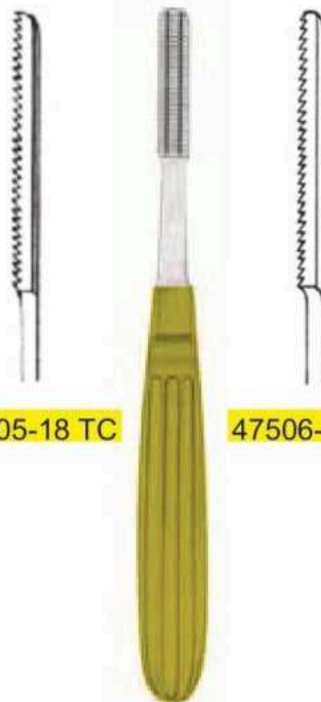

47505-18 TC

47506-18 TC

MALTZ
17,5 cm, 6.9"

Nasenraspeln
Nasal Rasps
Escofinas nasales
Raspa nasale

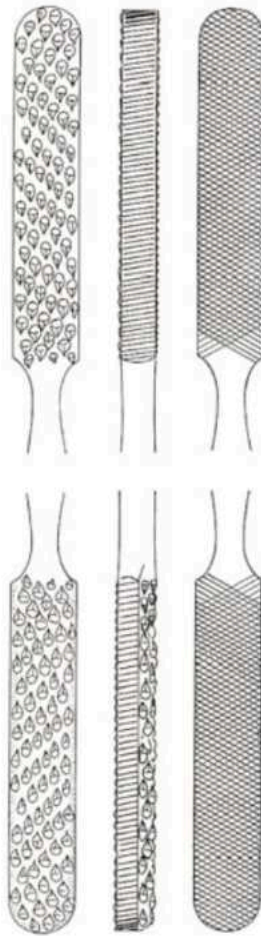

FOMON
47520-21
21 cm, 8¹/₄"

Nasenraspel
Nasal Rasps
Escofinas nasales
Raspa nasale

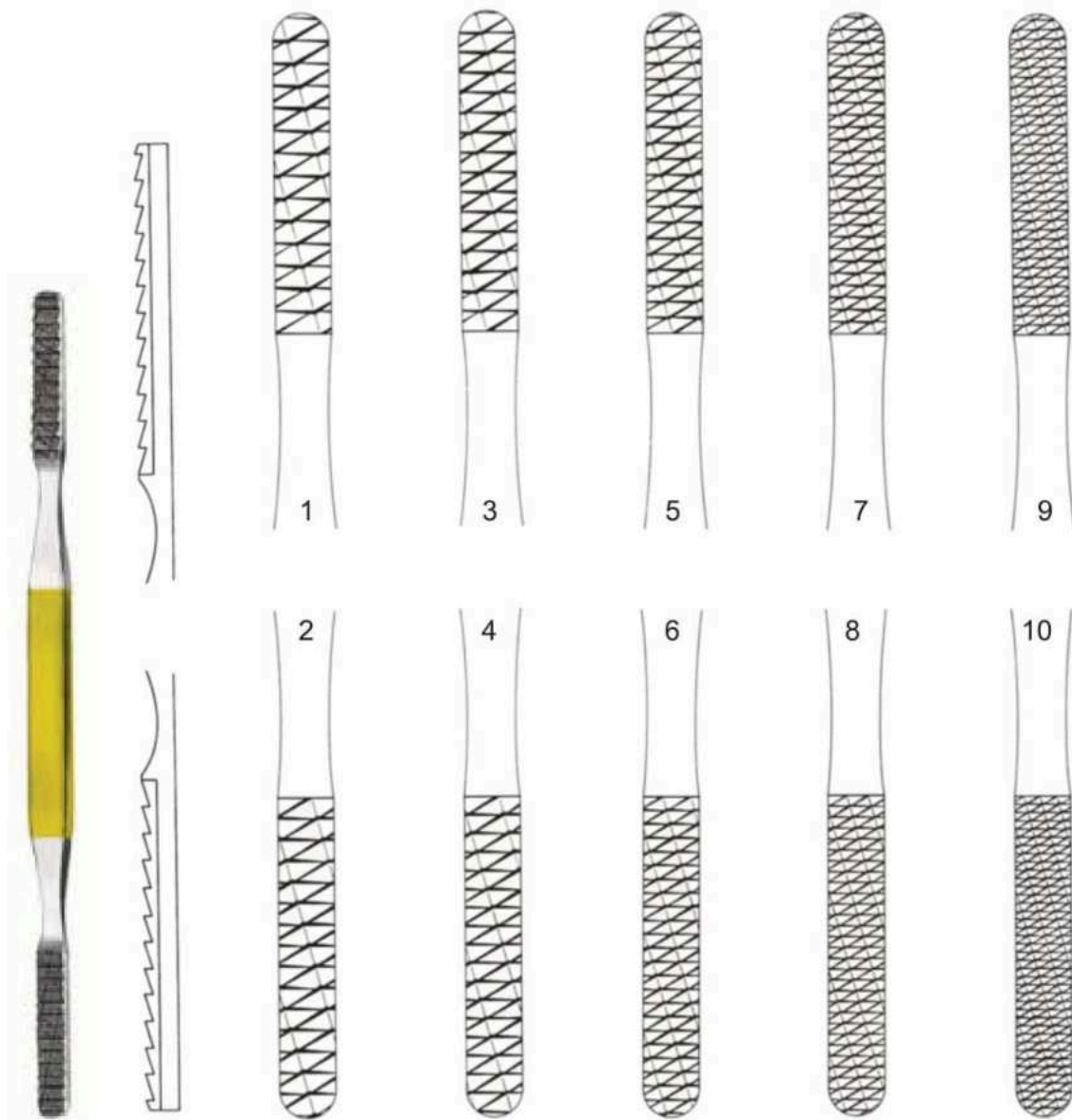

FOMON

47522-01TC - 47522-09 TC

20 cm, 8"

Fig. 1/2

47522-01 TC

Fig. 3/4

47522-04 TC

Fig. 5/6

47522-05 TC

Fig. 7/8

47522-07 TC

Fig. 9/10

47522-09 TC

Nasenraspeln, Nasensägen
 Nasal Rasps, Nasal Saws
 Escofinas nasales, Sierras nasales
 Raspa nasale, Seghe nasale



Nasensägen
Nasal Saws
Sierras nasales
Seghe nasale



JOSEPH
47535-01 17 cm, 6³/₄" 47535-02

Septumrichtzangen
Septum Straightening Forceps
Pinza para enderezar el tabique nasal
Pinza per la plastica nasale



ASCH
47571-23
23 cm, 9"



WALSHAM
47572-23
23 cm, 9"

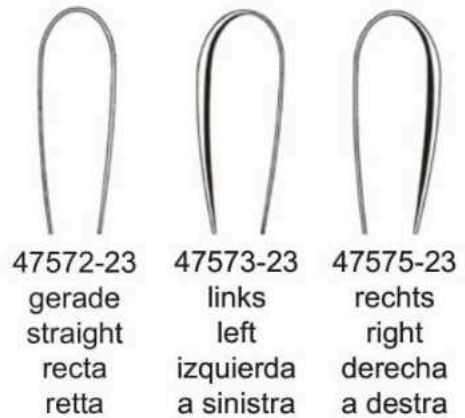

47572-23
gerade
straight
recta
retta

47573-23
links
left
izquierda
a sinistra

47575-23
rechts
right
derecha
a destra

Zungendrucker, Mundsperrer
 Tongue Depressors, Mouth Gags
 Boja-lengua, Abre-Bocas
 Abbassalingua, Apribocca



CL = mit Kaltlicht
 with cold light
 con luz fria
 con luce fredda

WIEDER



49115-01
 49115-01CL
 Fig. 1
 14 cm, 5 1/2"



49115-02
 49115-02CL
 Fig. 2
 15 cm, 6"

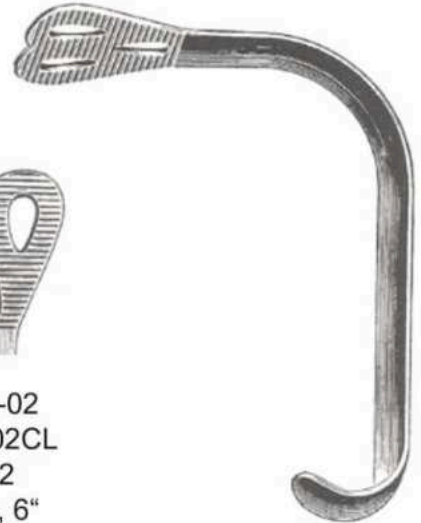

WIEDER



ANDREW
 49117-11
 11 cm, 4 3/8"

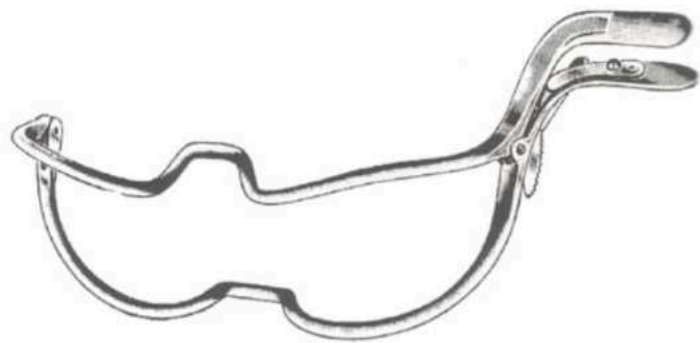

JENNINGS
 49274-09 9 cm, 3 1/2"
 49274-11 11 cm, 4 3/8"
 49274-13 13 cm, 5 1/8"
 49274-15 15 cm, 6"

Mundsperrer
Mouth Gags
Abre-Bocas
Apribocca



Sperrer allein
Gag only
Abre-boca suelto
Apribocca solo

DAVIS-BOYLE

links
left
izquierda
sinistra

rechts
right
derecha
destra

für Erwachsene
for adults
para adultos
per adulti

für Kinder
for children
para niños
per bambini

49310-10

49310-11

49310-12

49310-09

Mundsperrer
Mouth Gags
Abre-Bocas
Apribocca

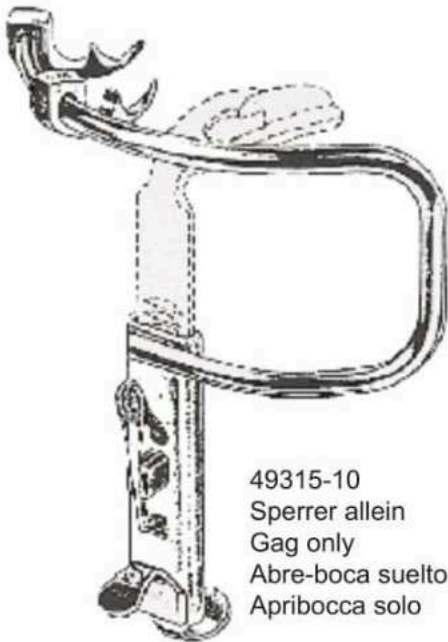

49315-10
Sperrer allein
Gag only
Abre-boca suelto
Apribocca solo



37x80 mm
49315-01
Fig.1



32x75 mm
49315-02
Fig.2



28x65 mm
49315-03
Fig.3

KILNER-DOUGHTY
49315-00
compl.

49317- 00 DINGMANN, komplett
mit 3 auswechselbaren Zungendrucker,
2 seitliche Wangenhaken und 2 Zahnhaken

with 3 interchangeable tongue depressors,
2 rotating cheek holders,
2 movable tooth hooks an thread guide

con 3 baja lenguas intercambiables
2 valvas giratorias p. los labios
2 ganchos graduables

con 3 depressori intercambiabili,
2 valve laterali rotative,
2 uncini a denti mobile

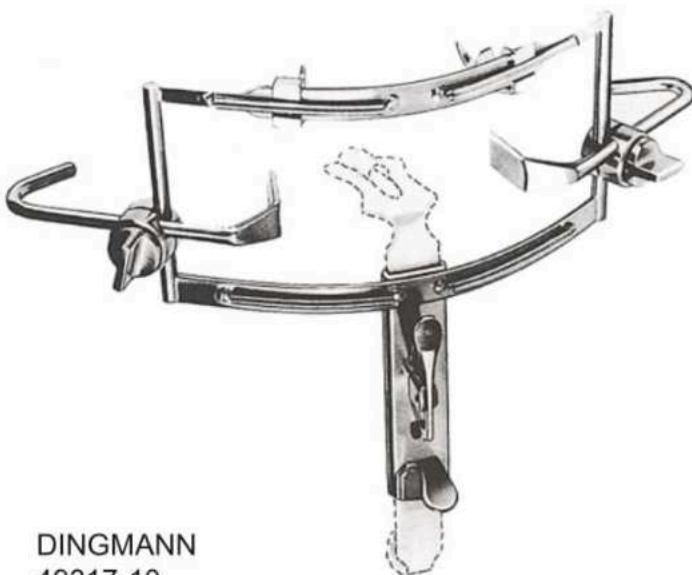

DINGMANN
49317-10
Sperrer allein, Gag only
Abre-boca suelto, Apribocca solo

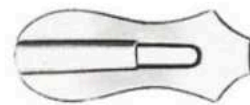

24x62 mm
49317-01
Fig. 1



28x65 mm
49317-02
Fig. 2



31x75 mm
49317-03
Fig. 3

Mundsperrer, Zungenspatel
 Mouth Gags, Tongue depressor
 Abre-Bocas, Baja-lengua
 Apribocca, Abbassalingua



McIVOR
 49320-00
 compl.

49320-10

49320-20
 Silikon-Schlauch
 Silicon Tubing
 tubo de silicona
 tubo in silicone

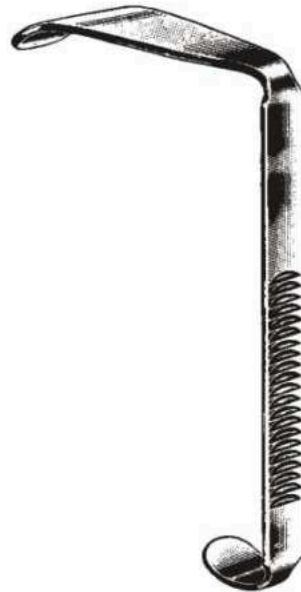

49320-01
 27x95 mm Fig.1



49320-02
 22x85 mm Fig.2

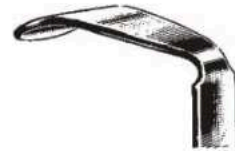

49320-03
 22x75 mm Fig.3



DAVIS-MEYER
 49340-00

Zungenspatel
Tongue blades
Baja-lenguas
Abbassalingua



Wundhaken für Mund-Kiefer-Gesicht
Retractors, Raspatories for Mouth-, Jaw- and Face Surgery
Separadores para cirugía de boca -mandíbula- fiscal
Divaricatori, Periostotomi per bocca, mascella, viso



OBWEGESER
22 cm, 8³/₄"

49605-07 25x7 mm

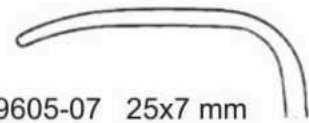

49605-10 31x10 mm

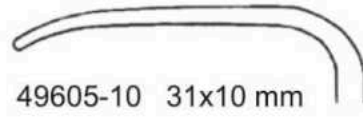

49605-11 42x11 mm

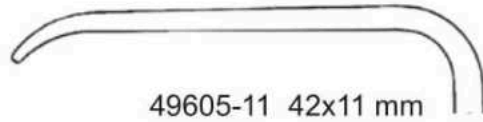

49605-12 55x12 mm

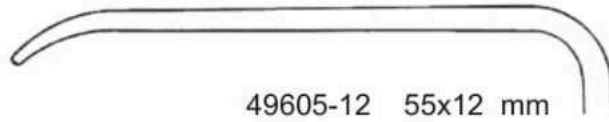

49605-14 70x14 mm

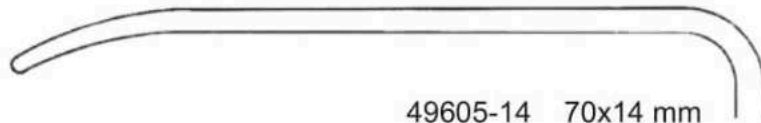

49605-16 80x16 mm



Wundhaken für Mund-Kiefer-Gesicht
Retractors, Raspatories for Mouth-, Jaw- and Face Surgery
Separadores para cirugía de boca -mandíbula- fiscal
Divaricatori, Periostotomi per bocca, mascella, viso



OBWEGESER
22 cm, 8³/₄"

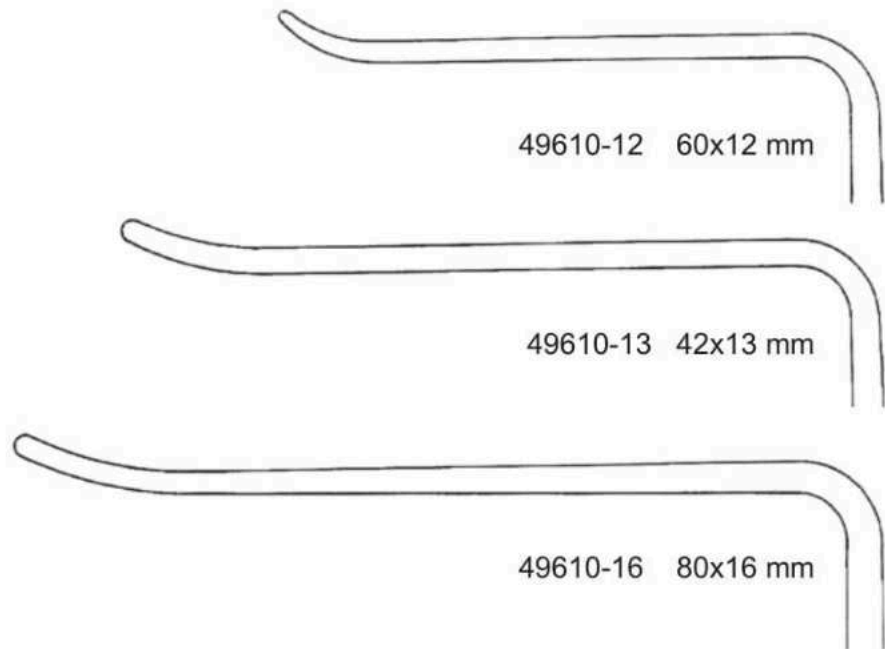

Wundhaken für Mund-Kiefer-Gesicht
 Retractors, Raspatories for Mouth-, Jaw- and Face Surgery
 Separadores para cirugía de boca- mandibula- fiscal
 Divaricatori, per bocca, mascella, viso

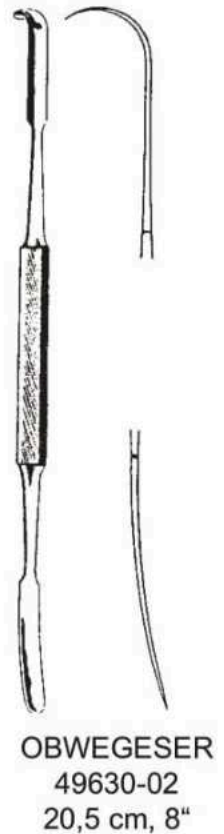
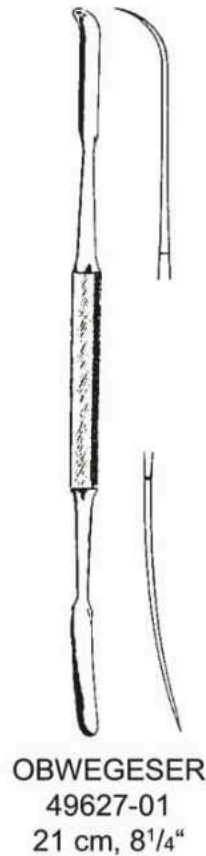
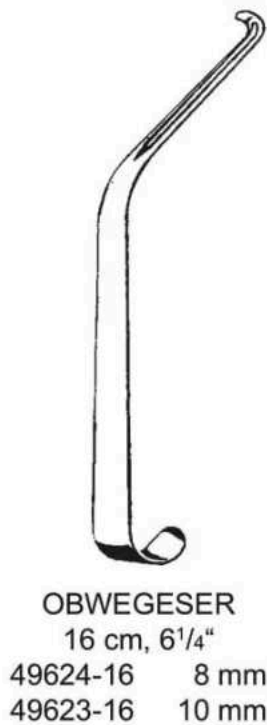
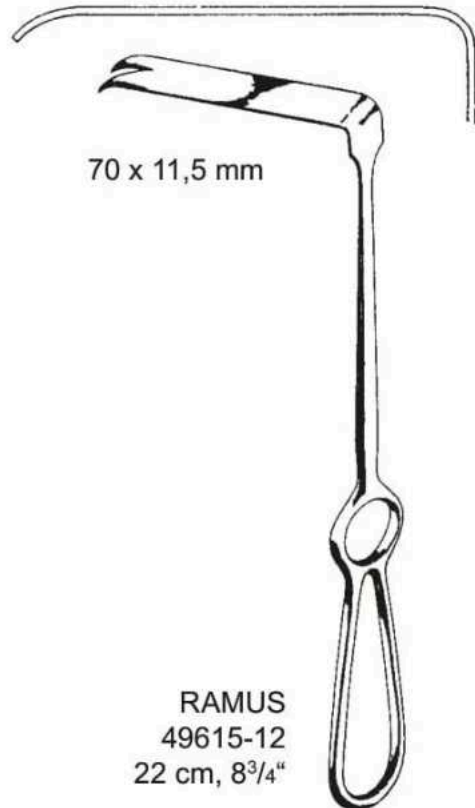
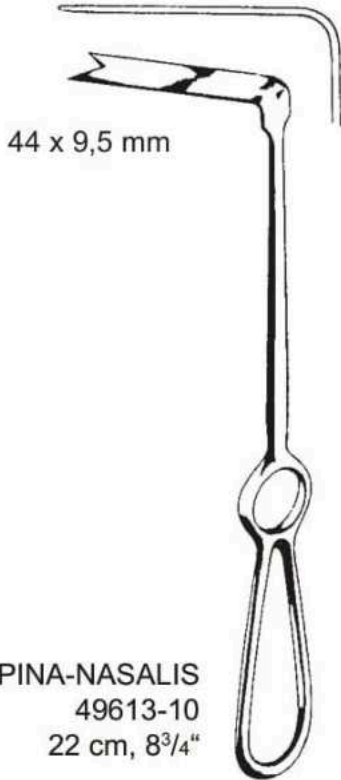

Raspatorien, Elevatoren
 Periosteal Elevators
 Legras
 Periostotomi

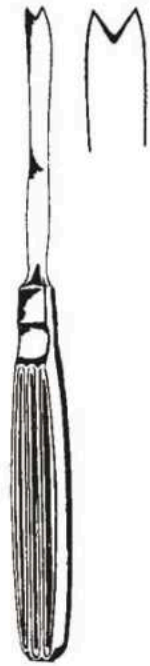

OBWEGESER
 49635-18 17,5 cm, 7"



OBWEGESER
 20 cm, 8"

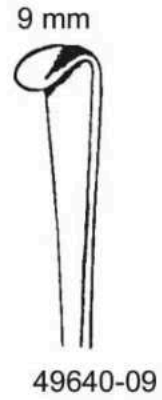

OBWEGESER
 17,5 cm, 7"



Raspator, Wundhaken, Elevator
 Raspatories, Retractor, Elevators
 Legras, Separadores, Elevadores
 Periostotomo, Divaricatore, Elevatore



DINGMAN
 49660-18 18 cm, 7"



19 cm, 7 1/2"

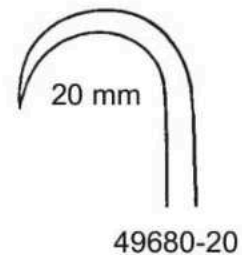
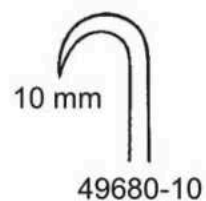

DINGMAN
 49685-21 21 cm, 8 1/4"

links left izquierda sinistra
 rechts right derecha destra



TESSIER
 49691-15 15 cm, 6"

TESSIER
 49692-15 15 cm, 6"

Osteotome
Osteotome
Osteótomos
Osteotomi



49666-10 10 mm
49666-15 15 mm
49666-20 20 mm

TESSIER
20,5 cm 8"



49667-10 10 mm
49667-15 15 mm

TESSIER
20,5 cm 8"



7 mm

49700-01
21,5 cm, 8 1/2"



10 mm

49700-02
21,5 cm, 8 1/2"

Endoskopische Instrumente
Endoscopic Instruments
Instrumentos para endoscopia
Strumenti endoscopici

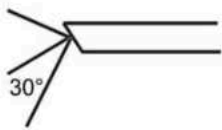
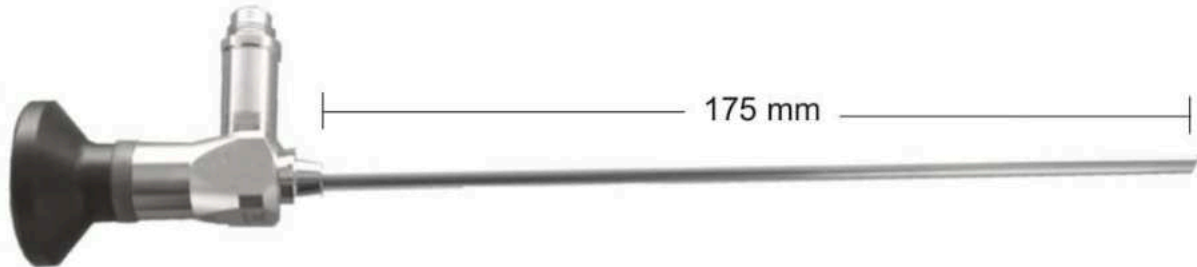

Vorausblick	30°	R600-040175-030
Foroblique vision	30°	
Visión hacia adelante	30°	
Grandangolo, visione	30°	

Endoskop für plastische Chirurgie 4 mm Ø, 30° Blickrichtung, 175 mm Nutzlänge, autoklavierbar, integrierte Faser für Ausleuchtung

Endo-Plastic-Scope 4 mm Ø, 30° direction of view, 175 mm working length, autoclavable, integrated fiberoptic bundle for illumination

Optica para endoplastia de 4 mm Ø, vision de 30°, largo útil de 175 mm, autoclavable, con fibra-optica para la iluminación

Ottica per endoplastica 4 mm Ø, visione 30°, lunghezza utile 175 mm, autoclavabile con fibre ottiche per illuminazione

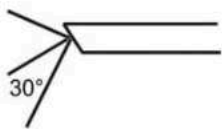
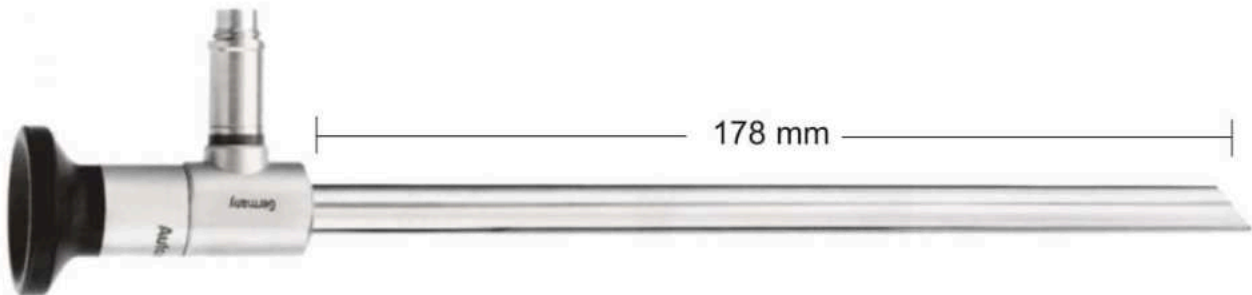

Vorausblick	30°	R600-100178-030
Foroblique vision	30	
Visión hacia adelante	30°	
Grandangolo, visione	30°	

Endo-Plastik-Optik 10 mm Ø, 30° Blickrichtung, 178 mm Nutzlänge, autoklavierbar, integrierte Fiberoptik für Ausleuchtung

Endo-Plastic-Scope 10 mm Ø, 30° direction of view, 178 mm working length, autoclavable, integrated fiberoptic bundle for illumination

Optica para endoplastia de 10 mm Ø, vision de 30°, largo útil de 178 mm, autoclavable, con fibra-optica para la iluminación

Ottica per endoplastica 10 mm Ø, visione 30°, lunghezza utile 178 mm, autoclavabile con fibre ottiche per illuminazione

Endoskopische Instrumente
Endoscopic Instruments
Instrumentos para endoscopia
Strumenti endoscopici



Schaft für Plastische Chirurgie mit 1 Hahn, drehbar, passend für 4 mm Optik mit 175 mm Nutzlänge

Endo-Plastic Sheath with spatula, 1 stopcock rotatable, for 4 mm scope with 175 mm work. length

Camisa para cirugía plástica, una llave giratoria, para óptica de 4 mm, largo útil de 175 mm

Camicia per chirurgia plastica, con spatola, 1 rubinetto rotante, per ottica 4 mm,
lunghezza 175 mm

7x17 mm gefenstert / 7x17 mm fenestrated
7x17 mm fenestrada / 7x17 mm fenestrata

R610-040175-070

11x17 mm gefenstert / 11x17 mm fenestrated
11x17 mm fenestrada / 11x17 mm fenestrata

R610-040175-110

11x23 mm gefenstert / 11x23 mm fenestrated
11x23 mm fenestrada / 11x23 mm fenestrata

R610-040175-115

Endoskopische Instrumente
Endoscopic Instruments
Instrumentos para endoscopia
Strumenti endoscopici



R610-040175-001

Schaft für Plastische Chirurgie, schnabelförmig, breit/flach, 1 Hahn, drehbar,
passend für 4 mm Optik mit 175 mm Nutzlänge

Endo-Plastic Sheath with oblique beak wide/flat, 1 stopcock rotatable,
suitable f. 4 mm scope with 175 mm working length

Camisa para cirugía plástica en forma de pico, ancho y plano, con una llave giratoria,
para óptica de 4 mm, largo útil de 175 mm

Camicia per chirurgia plastica, a forma di becco, larga/piatta, 1 rubinetto rotante,
per ottica 4 mm, lunghezza utile 175 mm

Endoskopische Instrumente
Endoscopic Instruments
Instrumentos para endoscopia
Strumenti endoscopici



R610-040175-005

Schaft für Plastische Chirurgie, schnabelförmig, 1 Hahn, drehbar, passend für 4 mm Optik mit 175 mm Nutzlänge

Endo-Plastic Sheath with oblique beak, 1 stopcock rotatable, suitable f. 4 mm scope with 175 mm working length

Camisa para cirugía plástica en forma de pico, con una llave giratoria, para óptica de 4 mm, largo útil de 175 mm

Camicia per chirurgia plastica, a forma di becco, 1 rubinetto rotante, per ottica 4 mm, lunghezza utile 175 mm

Endoskopische Instrumente
Endoscopic Instruments
Instrumentos para endoscopia
Strumenti endoscopici



R631-030160-110

Schere gerade, drehbar für rechte und linke Anwendung, 3 mm Ø, Griff mit HF-Anschluß, isoliert

Endoscopic Scissors, straight, insulated shaft, 3 mm Ø, handle with HF connector, rotatable

Tijera recta, giratoria, para su aplicación hacia la derecha y la izquierda, 3 mm Ø, mango con contacto de alta frecuencia, aislada

Forbice, retta, 3 mm Ø, rotante, per uso a destra e a sinistra, impugnatura con attacco per alta frequenza



R631-030160-112

Schere Metzenbaum, gebogen, drehbar für rechte und linke Anwendung, 3 mm Ø, Griff mit HF-Anschluß, isoliert

Endoscopic Metzenbaum Scissor, curved, insulated shaft, 3 mm Ø, handle with HF connector, rotatable

Tijera curva, giratoria, para su aplicación hacia la derecha y la izquierda, 3 mm Ø, mango con contacto de alta frecuencia, aislada

Forbice Metzenbaum, curva, 3 mm Ø, rotante, per uso a destra e a sinistra, impugnatura con attacco per alta frequenza



R631-030160-116

Hakenschere, drehbar für rechte und linke Anwendung, 3 mm Ø, Griff mit HF-Anschluß, isoliert

Endoscopic Micro Hook Scissor, curved shaft for left or right hand, 3 mm Ø, handle with HF connector, rotatable

Tijera de pico, giratoria, para su aplicación hacia la derecha y la izquierda, 3 mm Ø, mango con contacto de alta frecuencia, aislada

Forbice ad uncino, curva, 3 mm Ø, rotante, per uso a destra e a sinistra, impugnatura con attacco per alta frequenza

Endoskopische Instrumente
Endoscopic Instruments
Instrumentos para endoscopia
Strumenti endoscopici



R631-030160-212

Maryland Faszange gebogen, drehbar, für rechte und linke Anwendung, 3 mm Ø, Griff mit HF-Anschluß, isoliert

Endoscopic Curved Grasper, rotating, insulated shaft for left and right, 3 mm Ø, handle with HF connector

Pinza de agarre raspar tipo Maryland, giratoria, para su aplicación hacia la derecha y la izquierda, 3 mm Ø, mango con contacto de alta frecuencia, aislada
Pinza da presa Maryland, curva, rotante, per uso a destra e a sinistra, Ø 3 mm, impugnatura con attacco per alta frequenza



R631-030160-224

Delphinzange, drehbar für rechte und linke Anwendung, 3 mm Ø, Griff mit HF-Anschluß, isoliert

Endoscopic Needle Nose Grasper, rotatable for left and right use, 3 mm Ø, handle with HF connector

Pinza de agarre en forma de delfino, giratoria, para su aplicación hacia la derecha y la izquierda, 3 mm Ø, mango con contacto de alta frecuencia, aislada
Pinza da presa, rotante, per uso a destra e a sinistra, morso a delfino, Ø 3 mm, impugnatura con attacco per alta frequenza



R631-030160-246

Faßzange, retrograd gezahnt, drehbar für rechte und linke Anwendung, 3 mm Ø, Griff mit HF-Anschluß, isoliert

Endoscopic Heavy Grasper, rotatable for left and right, insulated, 3 mm Ø, handle with HF connector

Pinza de agarre, con dentadura en forma retrógrada, giratoria, para la aplicación hacia la derecha y la izquierda, 3 mm Ø, mango con contacto de alta frecuencia, aislada

Pinza da presa, retrograda, rotante, per uso a destra e a sinistra, 3 mm Ø, impugnatura con attacco per alta frequenza

Endoskopische Instrumente
Endoscopic Instruments
Instrumentos para endoscopia
Strumenti endoscopici

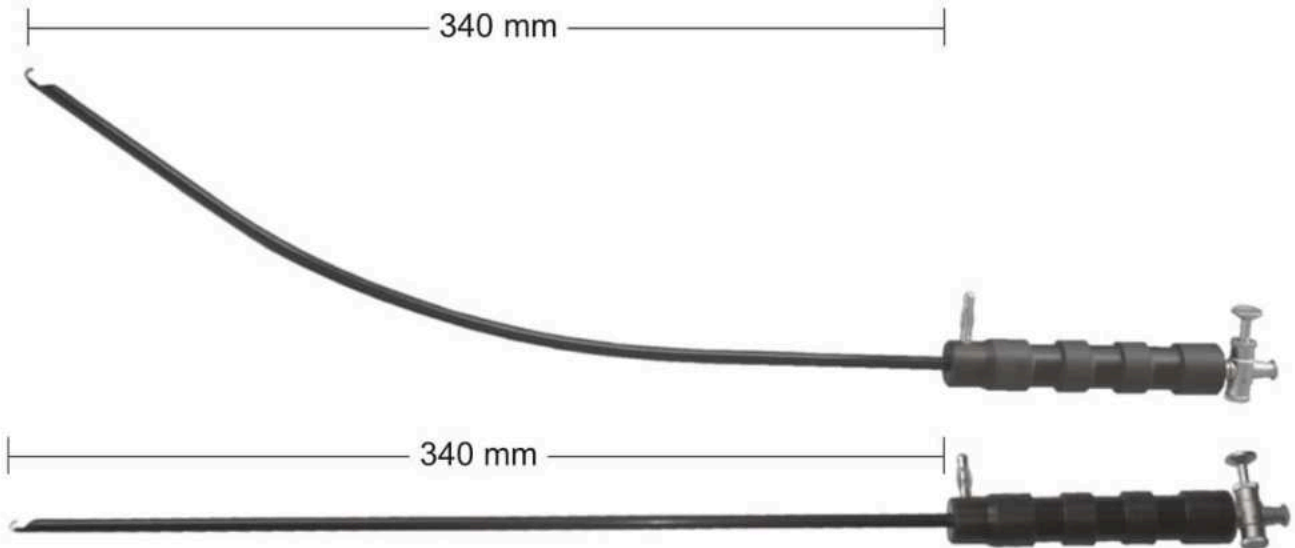

Monopolare Elektroden mit Saugkanal und Hahn, 5 mm Ø, 340 mm Nutzlänge
Monopolare electrodes with suction port and stopcock, 5 mm Ø, 340 mm working length
Electrodos monopolares con canal de succión y llave de 5 mm Ø, largo útil de 340 mm
Elettrodi monopolari con canale d'aspirazione e rubinetto, 5 mm Ø, lunghezza utile 340 mm



J-Haken Elektrode, gerade
J-Hook electrode straight
Electroda forma de gancho, recta
Elettrodo ad uncinetto, retto

R660-050340-002

J-Haken Elektrode, gebogen
J-Hook electrode curved
Electroda forma de gancho, curva
Elettrodo ad uncinetto, curvo

R661-050340-002



Spatel Elektrode, gerade
Spatula electrode straight
Electroda en forma de espátula, recta
Elettrodo a spatola, retto

R660-050340-004

Spatel Elektrode, gebogen
Spatula electrode curved
Electroda en forma de espátula, curva
Elettrodo a spatola, curvo

R661-050340-004

Liposuction-Kanülen
Liposuction cannulas
Cánulas de liposucción
Cannule per liposuzione



20 cm, 8" Ø 3 mm **40010-30**
30 cm, 12" Ø 3 mm **40011-30**
30 cm, 12" Ø 4 mm **40012-40**
40 cm, 16" Ø 4 mm **40013-40**
30 cm, 12" Ø 5 mm **40014-50**
30 cm, 12" Ø 6 mm **40015-60**



20 cm, 8" Ø 3 mm **40030-30**
30 cm, 12" Ø 3 mm **40031-30**
30 cm, 12" Ø 4 mm **40032-40**
30 cm, 12" Ø 5 mm **40032-50**
30 cm, 12" Ø 6 mm **40034-60**



5 cm, 2" Ø 2 mm **40050-20**
5 cm, 2" Ø 3 mm **40051-30**
5 cm, 2" Ø 4 mm **40052-40**
15 cm, 6" Ø 2 mm **40053-20**
15 cm, 6" Ø 3 mm **40054-30**
25 cm, 10" Ø 3 mm **40055-30**
25 cm, 10" Ø 4 mm **40056-40**
30 cm, 12" Ø 3 mm **40057-30**
30 cm, 12" Ø 5 mm **40058-50**



15 cm, 6" Ø 2 mm **40090-20**
15 cm, 6" Ø 3 mm **40091-30**
15 cm, 6" Ø 4 mm **40092-40**
25 cm, 10" Ø 3 mm **40093-30**
25 cm, 10" Ø 4 mm **40094-40**
25 cm, 10" Ø 5 mm **40095-50**
30 cm, 12" Ø 5 mm **40096-50**



20 cm, 8" Ø 3 mm **40020-30**
30 cm, 12" Ø 3 mm **40021-30**
30 cm, 12" Ø 4 mm **40022-40**
30 cm, 12" Ø 5 mm **40023-50**
30 cm, 12" Ø 6 mm **40024-60**



30 cm, 12" Ø 4 mm **40040-40**
30 cm, 12" Ø 5 mm **40041-50**



20 cm, 8" Ø 3 mm **40060-30**
30 cm, 12" Ø 3 mm **40061-30**



30 cm, 12" Ø 6 mm **40070-60**
35 cm, 14" Ø 6 mm **40071-60**



25 cm, 10" Ø 2 mm **40080-20**
35 cm, 14" Ø 3 mm **40081-20**



30 cm, 12" Ø 3 mm **40100-30**

Liposuction-Kanülen
 Liposuction cannulas
 Cánulas de liposucción
 Cannule per liposuzione



◀ LL



LL ▼

5 cm, 2"	Ø 1,7 mm		40110-17	40120-17
5 cm, 2"	Ø 2,0 mm		40111-20	40121-20
5 cm, 2"	Ø 3,0 mm		40112-30	40122-30
10 cm, 4"	Ø 2,0 mm		40113-20	40123-20
15 cm, 6"	Ø 1,7 mm		40114-17	40124-17
15 cm, 6"	Ø 2,0 mm		40115-20	40125-20
15 cm, 6"	Ø 3,0 mm		40116-30	40126-30



LL ▼

10 cm, 4"	Ø 1,7 mm	Ø 0,5 mm	40130-17	40140-17
10 cm, 4"	Ø 2,0 mm	Ø 1,0 mm	40131-20	40141-20
15 cm, 6"	Ø 2,0 mm	Ø 1,0 mm	40132-30	40142-30



LL ▼

15 cm, 6"	Ø 2,0 mm	Ø 1,0 mm	18	40150-20	40160-20
15 cm, 6"	Ø 2,5 mm	Ø 1,2 mm	18	40151-25	40161-25
15 cm, 6"	Ø 3,0 mm	Ø 1,5 mm	18	40152-30	40162-30
20 cm, 8"	Ø 2,5 mm	Ø 1,2 mm	22	40153-25	40163-25
20 cm, 8"	Ø 3,0 mm	Ø 1,5 mm	22	40154-30	40164-30
20 cm, 8"	Ø 4,0 mm	Ø 2,0 mm	22	40155-40	40164-40
25 cm, 10"	Ø 2,5 mm	Ø 1,2 mm	26	40156-25	40166-25
30 cm, 12"	Ø 3,0 mm	Ø 1,5 mm	30	40157-30	40167-30
30 cm, 12"	Ø 4,0 mm	Ø 2,0 mm	30	40158-40	40168-40

Liposuction-Kanülen
Liposuction cannulas
Cánulas de liposucción
Cannule per liposuzione



Griffansatz
Handle connector
Emplame mango
Attacco-manico



◀ LL

Luer-Lock Ansatz
Luer-Lock connector
Emplame Luer-Lock
Attacco Luer-Lock



LL ▼

20 cm, 8" Ø 3,0 mm 40170-30 40180-30



20 cm, 8"	Ø 3,0 mm	Ø 1,5 mm	22	40190-30	40200-30
20 cm, 8"	Ø 4,0 mm	Ø 2,0 mm	22	40191-40	40201-40
30 cm, 12"	Ø 3,0 mm	Ø 1,5 mm	30	40192-30	40202-30
30 cm, 12"	Ø 4,0 mm	Ø 2,0 mm	30	40193-40	40203-40

LL ▼



Handgriffe für Kanülen
 Handles for cannulas
 Mangos para cánulas
 Manici per cannule



Ø 13 mm

40001-13
13 cm, 5¼"



40002-13
13 cm, 5¼"



360°

Ø 13 mm

40003-13
13 cm, 5¼"



360°

40004-13
13 cm, 5¼"



LL

40005-14
14 cm, 5½"



LL

40006-14
14 cm, 5½"



40000-40
Ø 40 mm



40000-50
5 cm, 2"

Liposuction-Kanülen
Liposuction cannulas
Cánulas de liposucción
Cannule per liposuzione



Ø 13 mm



15 cm, 6"	Ø 3 mm	40300-30
15 cm, 6"	Ø 6 mm	40301-60
25 cm, 10"	Ø 4 mm	40302-40
25 cm, 10"	Ø 6 mm	40303-60
30 cm, 12"	Ø 9 mm	40304-90



15 cm, 6"	Ø 4 mm	40400-40
25 cm, 10"	Ø 6 mm	40401-60
30 cm, 12"	Ø 6 mm	40402-60



15 cm, 6"	Ø 3 mm	40500-30
-----------	--------	-----------------



15 cm, 6"	Ø 6 mm	40501-60
25 cm, 10"	Ø 6 mm	40502-60

SET/100 Basic Plastic Surgery – Basis Set Plastische Chirurgie

1x	07103-00	scalpel handle no. 3
1x	07115-00	scalpel blade fig. 15
1x	09305-14	JOSEPH, scissors, cvd., 14,5 cm
1x	09310-12	KILNER, scissors, cvd., 12 cm
1x	09340-11	IRIS, scissors, str., 11 cm
1x	09341-11	IRIS, scissors, cvd., 11 cm
2x	11176-12	ADSON micro, dressing forceps, 12 cm
2x	11186-12	ADSON micro, tissue forceps, 1x2 t., 12 cm
4x	13220-12	HALSTED-MOSQUITO, forceps, str., 12,5 cm
6x	13221-12	HALSTED-MOSQUITO, forceps, cvd., 12,5 cm
2x	13320-14	ROCHESTER-OCHSNER, forceps, 1x2 t., str., 14 cm
4x	15111-09	BACKHAUS, towel forceps, 9 cm
2x	17170-18	FOERSTER, swab forceps, str., 18 cm
1x	19216-01	JOSEPH, hooklet, sharp, 1 prong, 16 cm
1x	19216-02	JOSEPH, hooklet, sharp, 2 prongs, 16 cm
1x	19650-10	WEITLANER, retractor, sharp, 11,5 cm
1x	21110-14	grooved director, 14,5 cm
1x	25137-11	BABY WEBSTER, needle holder TC, 11 cm
1x	25164-15	CRILE-WOOD, needle holder TC, 15 cm
1x	47560-18	GILLIES, hooklet, delicate, fig. 1, 18cm
2x	65110-15	ALLIS, tissue forceps, 4x5 t., 15 cm
1x	89127-08	bowl round, stainless steel, 80x40 mm, 0,14 l

SET/101 Abdominplasty Set – Abdominoplastik Set

1x	07104-00	scalpel handle no. 4
1x	07120-00	scalpel blade fig. 20
1x	09165-14	MAYO, scissors TC, cvd., 14,5 cm
1x	10039-23	KAYE, face lift Supercut scissors, cvd., 23 cm
1x	10011-19	GORNEY, face lift scissors, cvd., 18,5 cm
1x	11112-18	POTTS-SMITH, dressing forceps, 18 cm
1x	11126-18	POTTS-SMITH, tissue forceps, 1x2 t., 18 cm
1x	11176-12	ADSON micro, dressing forceps, 12 cm
1x	11186-12	ADSON mirco, tissue forceps, 1x2 t., 12 cm
1x	11188-12	ADSON-BROWN, tissue forceps, 7x7 t., 12 cm
6x	15111-13	BACKHAUS, towel forceps, 13 cm
1x	19102-12	FARABEUF, retractor, double pair, 12 cm
2x	19216-07	JOSEPH, hooklet, sharp, 2 prongs, 16 cm
1x	19364-60	ISRAEL, retractor, blunt, 50x60 mm, 25 cm
1x	25144-13	HALSEY, needle holder TC, 13 cm
1x	25184-16	MAYO-HEGAR, needle holder TC, 16 cm
1x	25184-20	MAYO-HEGAR, needle holder TC, 20 cm

SET/102 Skin Graft Set – Hautverpflanzung Set

1x	03350-15	tape measure metal, 1,5 m
1x	07103-00	scalpel handle no. 3
1x	07115-00	scalpel blade fig. 15
1x	07490-00	SCHINK, dermatome, 30 cm
1x	09283-15	METZENBAUM-FINO, scissors, cvd, 15 cm
1x	09283-18	METZENBAUM-FINO, scissors, cvd., 18 cm
1x	11260-15	SEMKEN. dressing forceps, 15,5 cm
1x	11270-15	SEMKEN, tissue forceps, 1x2 t., 15,5 cm
3x	13221-12	HALSTED-MOSQUITO, forceps, cvd., 12,5 cm
4x	15111-13	BACKHAUS, towel forceps, 13 cm
1x	19212-01	GUTHRIE, double hooklet, small, 12 cm
1x	19240-10	SENN-GREEN, retractor, 10x6mm, 15cm
1x	25214-18	DeBAKEY, needle holder TC, 18 cm
1x	25164-15	CRILE-WOOD, needle holder TC, 15 cm
1x	47560-18	GILLIES, hooklet, delicate, fig. 1, 18 cm
2x	65110-15	ALLIS, tissue forceps, 4x5 t., 15 cm

SET/103 Nose Correction – Nasenkorrektur Set

1x	07107-00	scalpel handle no. 7
1x	07115-00	scalpel blade fig. 15
1x	09304-14	JOSEPH, scissors, str., 14 cm
1x	09310-12	KILNER, scissors, cvd., 12 cm
1x	09321-15	REYNOLDS, scissors, cvd., 15 cm
1x	09401-18	HEYMANN, scissors, 18 cm
1x	11176-12	ADSON micro, dressing forceps, 12 cm
1x	11186-12	ADSON micro, tissue forceps, 1x2 t., 12 cm
1x	11188-12	ADSON-BROWN, tissue forceps, 7x7 t., 12 cm
1x	13220-12	HALSTED-MOSQUITO, forceps, str., 12,5 cm
1x	13223-12	HALSTED-MOSQUITO, forceps, cvd., 12,5 cm
1x	13312-14	PEAN, forceps, str., 14 cm
4x	15111-13	BACKHAUS, towel forceps, 13 cm
1x	17111-20	GROSS-MAIER, dressing forceps, cvd., 20 cm
1x	19212-01	GUTHRIE, double hooklet, 12 cm
1x	19216-02	JOSEPH, hooklet, sharp, 2 prongs, 16 cm
1x	19218-01	BARSKY, hook, 15 cm
1x	19230-12	DESMARRES, retractor, 16 cm
1x	25137-11	BABY WEBSTER, needle holder TC, 11 cm
1x	25164-15	CRILE-WOOD, needle holder TC, 15 cm
1x	33100-01	FRIEDMAN micro, bone rongeur, str., 14 cm
1x	33694-01	mallet with interchangeable plastic, 18,5 cm
1x	33711-16	WILLIGER, raspatory, str., 16cm
1x	33711-20	LANGENBECK, elevator, 20 cm
1x	45206-14	LUCAE, ear forceps, 14 cm
1x	47120-35	KILLIAN, nasal speculum, 35 mm, 13 cm
1x	47120-50	KILLIAN, nasal speculum, 50 mm, 13 cm
1x	47224-01	WEIL-BLAKESLEY, forceps, fig. 1, 45°, 3 mm
1x	47256-20	CAPLAN, nasal cutting forceps, 20 cm
1x	47347-20	GUILLEN, suction raspatory, 19 cm
1x	47374-16	FREER, mucosa knife, 16,5 cm
1x	47423-22	COTTLE, septum elevator, 22 cm
1x	47454-04	COTTLE, rhinoplastic osteotome, 18 cm
1x	47454-07	COTTLE, rhinoplastic osteotome, 18 cm
1x	47470-04	FOMON, osteotome, 17 cm
1x	47522-05	FOMON, nasal raspel TC, fig. 5/6, 20 cm
1x	47551-16	AUFRIECHT, nasal retractor, 16 cm
1x	47555-08	KILNER, nasal retractor, 8 cm
1x	47565-10	COTTLE, columella forceps, 10 cm
1x	47571-23	ASCH, septum forceps, str., 23 cm
1x	89127-08	bowl round, stainless steel, 80x40 mm, 0,14 l

SET/104 Face Lift Set

1x	03370-16	PITANGUY, facelift marker, 16 cm
1x	07107-00	scalpel handle no. 7
1x	07115-00	scalpel blade fig. 15
1x	09345-11	IRIS, scissors TC, cvd., 11 cm
1x	10015-19	GORNEY, face lift Supercut scissors, cvd., 18,5 cm
1x	10045-14	PECK-JOSEPH, dissecting scissors, cvd., 14,5 cm
1x	11176-12	ADSON micro, dressing forceps, 12 cm
1x	11186-12	ADSON micro, tissue forceps, 1x2 t., 12 cm
1x	11188-12	ADSON-BROWN, tissue forceps, 7x7 t., 12 cm
1x	11231-20	BROPHY, tissue forceps, 1x2 t., 20 cm
1x	13364-14	MARTEL, scalp flap forceps, 14 cm
1x	19102-12	FARABEUF, retractor double pair, 12 cm
1x	19216-02	JOSEPH, hooklet, sharp, 2 prongs, 16 cm
1x	19314-16	KOCHER-LANGENBECK, retractor, 21 cm
1x	19995-38	FREEMAN, retractor, sharp, 4 prongs, 18 cm
1x	25144-13	HALSEY, needle holder TC, 13 cm
1x	25164-15	CRILE-WOOD, needle holder TC, 15 cm
1x	47560-18	GILLIES, hooklet, delicate, fig. 1, 18 cm

**SET/105 Eyelid Plastic (Blepharoplasty) –
Set zur Lidstraffung (Blepharoplastik)**

1x	07103-00	scalpel handle no. 3
1x	07115-00	scalpel blade fig. 15
1x	09341-11	IRIS, scissors, cvd., 11 cm
1x	09362-11	STEVENS, scissors, str. 11 cm
1x	10313-14	GOMEL, scissors, cvd., 14 cm
1x	11186-12	ADSON micro, tissue forceps, 1x2 t., 12 cm
1x	13220-12	HALSTED-MOSQUITO, forceps, str., 12,5 cm
1x	13221-12	HALSTED-MOSQUITO, forceps, cvd., 12,5 cm
4x	15111-09	BACKHAUS, towel forceps, 9 cm
1x	19216-01	JOSEPH, hooklet, sharp, 1 prong, 16 cm
1x	19216-02	JOSEPH, hooklet, sharp, 2 prongs, 16 cm
1x	19230-12	DESMARRES retractor, 16 cm
1x	25670-14	CASTROVIEJO, needle holder, str., 14 cm
1x	44150-01	CASTROVIEJO, suturing forceps, 0,1 mm, 10 cm
1x	47560-18	GILLIES, hooklet, delicate, fig. 1, 18 cm

SET/106 Mammoplasty – Mammoplastik Set

1x	03340-20	ruler metal, 20 cm
1x	03500-38	FREEMAN, marker, 38 mm
1x	03500-42	FREEMAN, marker, 42 mm
1x	03500-44	FREEMAN, marker, 44 mm
1x	07107-00	scalpel handle no. 7
1x	07115-00	scalpel blade fig. 15
1x	09281-18	METZENBAUM, scissors, 18 cm
1x	09310-15	KILNER, scissors, 15 cm
1x	09583-15	neurosurgery scissors, cvd., 15 cm
1x	11102-14	dressing forceps, 14,5 cm
1x	11186-12	ADSON micro, tissue forceps, 1x2 t., 12 cm
2x	13223-12	HALSTED-MOSQUITO, micro, forceps, cvd., 12,5 cm
2x	13231-12	HALSTED-MOSQUITO, forceps, cvd., 12,5 cm
1x	13475-18	MIXTER BABY, forceps, 18 cm
6x	15111-13	BACKHAUS, towel forceps, 13 cm
1x	17110-25	GROSS-MAIER, dressing forceps, 25 cm
1x	19102-12	FARABEUF, retractor double par, 12 cm
1x	19314-12	KOCHER-LANGENBECK, retractor, 21 cm
1x	19999-00	AGRIS-DINGMAN, breast dissector, set of 2, 36 cm
1x	19999-02	TEBBETTS, breast dissector, 33 cm
1x	25164-15	CRILE-WOOD, needle holder TC, 15 cm
1x	25180-16	MAYO-HEGAR, needle holder, 16 cm
1x	47154-20	JANSEN, nasal forceps, 20 cm
1x	89127-08	bowl round, stainless steel, 80x40mm, 0,14 l

03312-012	07109-10 11	09280-20 16	09345-11.....20	09825-1225
03314-012	07109-13 11	09280-23 16	09346-11.....20	09826-1225
03340-102	07109-15 11	09281-12 16	09348-0121	09828-1225
03340-152	07161-00 11	09281-15 16	09348-0221	09829-1225
03340-202	07162-00 11	09281-18 16	09348-0321	09854-11.....26
03340-302	07165-00 11	09281-20 16	09348-0421	09855-11.....26
03340-502	07167-00 11	09281-23 16	09348-0521	09962-14 13
03370-163	07296-007	09282-15 17	09348-0621	09962-17 13
03380-303	07490-006	09282-18 17	09349-1222	09963-14 13
03390-303	07490-016	09282-20 17	09350-0923	09963-17 13
03400-385	07490-026	09282-23 17	09350-1022	09964-15 14
03400-425	07495-317	09283-15 17	09351-0923	09964-17 14
03400-455	07496-317	09283-18 17	09352-0923	09965-15 14
03500-344	07498-007	09283-20 17	09352-1022	09965-17 14
03500-364	07499-007	09283-23 17	09353-0923	09966-11..... 16
03500-384	07499-017	09284-12 16	09354-1023	09967-11..... 16
03500-424	09160-14 13	09284-15 16	09355-1023	09970-14 16
03500-454	09160-17 13	09284-18 16	09356-1023	09970-18 16
03500-504	09161-14 13	09284-20 16	09357-1023	09970-20 16
03501-344	09161-17 13	09284-23 16	09358-11.....22	09970-23 16
03501-384	09164-14 13	09285-12 16	09360-11.....24	09971-14 16
03501-454	09164-17 13	09285-15 16	09361-11.....24	09971-18 16
03505-004	09165-14 13	09285-18 16	09362-11.....24	09971-20 16
03520-344	09165-17 13	09285-20 16	09363-11.....24	09971-23 16
03520-384	09170-15 14	09285-23 16	09370-11.....24	09980-11.....20
03520-454	09170-17 14	09286-15 17	09371-11.....24	09981-11.....20
03530-344	09171-15 14	09286-18 17	09374-11.....24	09982-1225
03530-364	09171-17 14	09286-20 17	09375-11.....24	09983-1225
03530-384	09174-15 14	09286-23 17	09401-1827	09984-11.....24
03530-424	09174-17 14	09287-15 17	09403-1527	09985-11.....24
03530-454	09175-15 14	09287-18 17	09405-1627	09993-15 19
03530-504	09175-17 14	09287-20 17	09405-16TC...27	09995-12 19
03540-324	09190-16 15	09287-23 17	09406-1027	10010-19 30
03540-374	09191-16 15	09302-14 18	09407-1027	10011-19.....30
03540-434	09194-16 15	09303-14 18	09540-16 19	10012-19 30
03550-145	09195-16 15	09304-14 18	09541-16 19	10013-19 30
03550-165	09202-10 15	09305-14 18	09542-16 19	10014-19 30
03560-345	09203-10 15	09310-12 19	09543-16 19	10015-19 30
03560-385	09206-10 15	09310-15 19	09544-16 19	10028-14 31
03560-425	09207-10 15	09314-12 19	09545-16 19	10029-14 31
07103-008	09270-15 17	09321-15 19	09614-1929	10030-18 31
07103-018	09270-18 17	09321-18 19	09617-1327	10031-18 31
07103-028	09271-15 17	09340-09 20	09802-09 28	10032-23 31
07104-009	09271-18 17	09340-10 20	09802-11.....28	10033-23 31
07104-029	09274-15 17	09340-11.....20	09804-1428	10034-14 31
07105-029	09274-18 17	09341-0920	09805-0928	10035-14 31
07106-019	09275-15 17	09341-1020	09820-1329	10036-18 31
07107-0010	09275-18 17	09341-11.....20	09821-1329	10037-18 31
07107-0110	09280-12 16	09342-08 20	09821-13SC ..29	10038-23 31
07108-0010	09280-15 16	09343-08 20	09823-1225	10039-23 31
07109-038	09280-18 16	09344-11.....20	09824-1225	10044-14 31

10045-1431	10227-11.....35	11114-1636	11177-12.....38	11274-06.....43
10048-1431	10227-1435	11114-2036	11178-12.....38	11274-08.....43
10049-1431	10227-1835	11114-2536	11179-12.....38	11274-10.....43
10050-1431	10227-18T35	11116-1836	11180-12.....39	11302-17.....43
10050-1831	10227-2135	11116-2136	11180-12F.....39	11302-23.....43
10051-1431	10227-2335	11116-2536	11180-15.....39	11303-17.....43
10051-1831	10228-11.....35	11120-1037	11181-12.....39	11304-17.....43
10061-1930	10228-1435	11120-1137	11181-15.....39	11305-17.....44
10061-19SC ..30	10228-1835	11120-1337	11182-12.....39	11310-17.....44
10061-19TC...30	10228-18T35	11120-1437	11186-12.....39	11311-17.....44
10061-2330	10228-2135	11120-1637	11186-15.....39	11312-17.....44
10061-23SC ..30	10228-2335	11120-1837	11187-12.....39	11312-18.....44
10061-23TC...30	10229-11.....35	11120-2037	11187-18.....41	11313-17.....44
10201-11.....32	10229-1435	11122-1237	11187-20.....41	11314-01.....44
10201-11SC...32	10229-1835	11122-1337	11187-25.....41	11314-02.....44
10202-11.....33	10229-18T35	11122-1437	11187-30.....41	11315-01.....44
10202-1433	10229-2135	11122-1537	11188-12.....40	11315-02.....44
10202-14T33	10229-2335	11122-1837	11188-12F.....40	11316-14.....45
10202-1833	10230-11.....35	11122-2137	11188-15.....40	11316-16.....45
10202-18T33	10230-1435	11124-1537	11189-12.....40	11316-20.....45
10202-2133	10230-1835	11126-1836	11189-15.....41	11317-00.....45
10202-21T33	10230-18T35	11126-2136	11189-20.....41	11317-12.....45
10202-2333	10230-2135	11126-2536	11189-25.....41	11317-23.....45
10203-11.....33	10230-2335	11130-1137	11190-10.....41	11318-18.....45
10203-1433	11102-10.....36	11130-1337	11191-12.....40	11318-20.....45
10203-14T33	11102-1136	11130-1437	11220-17.....41	11318-25.....45
10203-1833	11102-1336	11130-1637	11221-17.....41	11319-12.....45
10203-18T33	11102-1436	11130-1837	11222-17.....41	11319-14.....45
10203-2133	11102-1636	11130-2037	11223-17.....41	11320-18.....45
10203-21T33	11102-1836	11132-1637	11224-17.....41	11320-23.....45
10203-2333	11102-20.....36	11132-1837	11225-17.....41	11401-01.....46
10206-11.....32	11103-1436	11132-2037	11232-15.....41	11403-03.....46
10206-11SC...32	11104-12.....36	11140-1137	11246-18.....42	11403-04.....46
10207-11.....32	11104-13.....36	11140-1337	11248-18.....42	11404-04.....46
10207-11SC...32	11104-1436	11140-1437	11250-14.....42	11405-05.....46
10220-0034	11104-15.....36	11140-1637	11252-20.....42	11407-07.....46
10220-00T34	11104-1836	11140-1837	11256-15.....42	12090-15D....47
10220-2534	11104-2136	11140-2037	11256-20.....42	12090-18D....47
10220-25T34	11106-13.....36	11150-1337	11256-25.....42	12090-21D....47
10220-4534	11106-15.....36	11150-1437	11257-15.....42	12090-23D....47
10220-45T34	11110-1136	11150-1637	11258-15.....42	12091-15D....47
10220-6034	11110-1336	11160-1337	11259-15.....42	12091-18D....47
10220-60T34	11110-1436	11160-1437	11260-12.....43	12091-21D....47
10220-9034	11110-1636	11160-1637	11260-15.....43	12091-23D....47
10220-90T34	11110-1836	11170-1238	11261-15.....43	12102-1247
10226-11.....35	11110-2036	11170-12F.....38	11270-12.....43	12102-12D....47
10226-1435	11110-2536	11170-1538	11270-15.....43	12102-12T47
10226-1835	11112-1836	11174-1238	11271-15.....43	12102-2147
10226-18T35	11112-2136	11174-1538	11271-18.....43	12102-21D....47
10226-2135	11112-2536	11176-1238	11272-15.....43	12102-2347
10226-2335	11114-1436	11176-1538	11273-15.....43	12102-23D....47

12103-1247	12117-18.....50	13230-1860	13411-18.....64	19217-0570
12103-12D47	12117-21.....50	13230-2160	19102-1265	19217-0770
12103-1547	12117-23.....50	13231-1260	19102-1565	19218-0171
12103-15D47	12118-18.....50	13231-1460	19124-1565	19218-0271
12104-1547	12118-21.....50	13231-1860	19125-1465	19218-11.....71
12104-15D47	12118-23.....50	13231-2160	19127-11.....65	19220-0172
12104-15T47	12302-1651	13232-1260	19168-0666	19220-0272
12104-18T47	12302-2051	13233-1260	19168-0866	19220-0372
12104-21T47	12302-2451	13240-1461	19168-1066	19220-0472
12104-23T47	12304-1651	13240-1861	19168-1266	19221-0172
12108-12T47	12304-2051	13241-1461	19168-1766	19221-0272
12108-15T47	12304-2451	13241-1861	19168-2066	19221-0372
12108-1847	12304-3051	13242-1661	19168-2566	19221-0472
12108-18D47	12306-1651	13243-1661	19169-2566	19226-0272
12108-18T47	12306-2051	13244-1461	19170-2066	19226-0372
12108-21T47	12306-2451	13245-1461	19170-2566	19226-0472
12108-23T47	12306-3051	13250-1462	19170-3266	19227-0272
12109-1847	12308-1651	13250-1862	19170-4066	19227-0372
12109-18D47	12308-2051	13251-1462	19170-4566	19227-0472
12109-2147	12308-2451	13251-1862	19170-5066	19229-0272
12109-21D47	12308-3051	13254-1462	19170-6566	19229-0372
12109-2347	12309-1651	13255-1462	19170-7666	19230-1073
12109-23D47	12309-2051	13256-1461	19180-1967	19230-1273
12112-15D48	12309-2451	13257-1461	19181-2267	19230-1473
12112-15T48	12309-3051	13258-1661	19181-2567	19230-1673
12112-18D48	12310-1651	13259-1661	19183-2567	19230-1873
12112-18T48	12310-2051	13260-1462	19183-25CL...68	19234-0073
12112-21D48	12310-2451	13261-1462	19185-2567	19237-1673
12112-21T48	12310-3051	13262-1662	19187-2567	19270-0273
12112-23D48	13210-1059	13263-1662	19188-1268	19270-0373
12112-23T48	13211-10.....59	13264-1662	19188-12CL...68	19270-0473
12114-15D48	13212-1059	13265-1662	19188-2568	19270-0673
12114-15T48	13213-1059	13270-1461	19188-25CL...68	19271-0273
12114-18D48	13214-1059	13271-1461	19210-1269	19271-0373
12114-18T48	13215-1059	13310-1363	19211-12.....69	19271-0473
12114-21D48	13220-1260	13310-1463	19212-0169	19271-0673
12114-21T48	13220-1460	13310-1663	19212-0269	19302-0174
12114-23D48	13220-1860	13311-13.....63	19213-1269	19302-0274
12114-23T48	13220-2160	13311-14.....63	19214-1370	19302-0374
12115-15.....49	13221-1260	13311-16.....63	19214-1870	19302-0474
12115-15T49	13221-1460	13320-1363	19215-0170	19302-0574
12115-18.....49	13221-1860	13320-1463	19215-0270	19302-0674
12115-18T49	13221-2160	13320-1663	19215-0370	19307-0174
12115-21.....49	13222-1260	13321-1363	19215-1370	19307-0274
12115-21T49	13223-1260	13321-1463	19215-1870	19610-0775
12115-23.....49	13224-1260	13321-1663	19216-0170	19611-07.....75
12115-23T49	13225-1260	13380-1563	19216-0270	19620-0775
12116-15.....49	13226-1260	13381-1563	19216-0570	19620-1075
12116-18.....49	13227-1260	13382-1563	19216-0770	19621-0775
12116-21.....49	13230-1260	13383-1563	19216-1070	19621-1075
12116-23.....49	13230-1460	13410-1864	19217-0370	19630-1075

19631-1075	19998-0584	25214-2092	25672-23D.....96	33652-03132
19634-1075	19998-11.....84	25214-2392	25673-1496	33652-04132
19635-1075	19998-1284	25224-1393	25673-14D.....96	33652-05132
19650-1076	19999-0081	25224-1593	25673-14T96	33652-06132
19651-1076	19999-0181	25224-1893	25673-1896	33652-08132
19670-1476	19999-0281	25224-2093	25673-18D.....96	33652-10132
19671-1476	19999-0381	25225-1393	25673-18T96	33652-12132
19741-0177	19999-0482	25225-1593	25673-21T96	33652-15132
19741-0277	19999-0581	25225-1893	25674-1496	33654-02132
19741-0377	19999-0682	25225-2093	25674-1896	33654-03132
19741-0477	19999-1079	25230-1893	25674-2196	33654-04132
19741-0577	19999-2282	25230-2093	25675-1496	33654-05132
19741-0677	19999-2982	25405-1293	25675-1896	33654-06132
19741-0777	19999-3079	25406-1293	25676-1496	33654-08132
19741-0877	19999-30CL...79	25407-1293	25677-1496	33654-10132
19741-0977	19999-3181	25408-1293	25691-1896	33654-12132
19741-1077	19999-4079	25410-1493	25700-1895	33654-15132
19741-11.....77	19999-5079	25410-1793	25701-1895	33686-25100
19741-1277	19999-50CL...79	25414-1493	25720-1295	33693-32100
19741-1377	25110-12.....91	25414-1793	25720-12D.....95	33694-01100
19960-0178	25114-12.....91	25414-1893	25720-1395	33694-02100
19960-0278	25128-1391	25434-11.....94	25720-13D.....95	33694-03100
19960-0378	25129-1391	25434-1394	25720-1495	33696-75100
19960-0478	25130-1391	25434-1694	25720-14D.....95	33698-98100
19960-0578	25134-1391	25660-1295	25730-1895	33700-05100
19960-0678	25136-11.....91	25660-1395	25730-18D.....95	33711-16.....101
19960-0778	25137-11.....91	25660-1495	25730-2195	33711-20.....101
19970-0180	25140-1391	25661-1295	25730-21D.....95	33711-21.....101
19970-2380	25144-1391	25661-1395	25730-2395	33712-16101
19970-2480	25150-1292	25661-1495	25730-23D.....95	33713-17101
19980-0078	25150-1492	25668-1896	25731-1295	33718-16101
19980-0178	25154-1292	25668-2196	25731-1395	33719-17101
19980-0278	25154-1492	25668-2396	25731-1495	33720-19102
19980-0378	25160-1592	25670-1496	25731-1895	33720-21102
19980-0478	25160-1892	25670-1896	25731-18D.....95	34554-1597
19980-0578	25164-1592	25670-2196	25731-2195	34554-1897
19980-0678	25164-1892	25671-12D.....95	25731-21D.....95	34554-2097
19980-1884	25164-2092	25671-13D.....95	25731-2395	34555-1597
19989-2282	25164-2392	25671-1496	25731-23D.....95	34555-1897
19989-2982	25180-1292	25671-14D.....95	33100-0198	34555-2097
19990-1883	25180-1492	25671-1896	33100-0298	34556-1897
19991-1883	25180-1692	25672-1496	33101-1298	40000-40162
19992-3180	25180-1892	25672-14D.....96	33101-1498	40000-50162
19995-2284	25180-2092	25672-14T.....96	33201-1898	40001-13162
19995-3884	25184-1292	25672-1896	33211-15.....98	40002-13162
19996-0484	25184-1492	25672-18D.....96	33213-1598	40003-13162
19996-1884	25184-1692	25672-18T.....96	33280-1599	40004-13162
19997-0984	25184-1892	25672-2196	33281-1599	40005-14162
19998-0184	25184-2092	25672-21D.....96	33282-1999	40006-14162
19998-0284	25214-1692	25672-21T.....96	33283-1799	40010-30159
19998-0384	25214-1892	25672-2396	33652-02132	40011-30.....159

40012-40 159	40125-20 160	41069-20 85	44150-15 55	47169-18 118
40013-40 159	40126-30 160	41290-21 107	44254-09 55	47185-18 118
40014-50 159	40130-17 160	41295-06 108	44256-09 55	47191-01 119
40015-60 159	40131-20 160	41295-07 108	44258-09 55	47191-02 119
40020-30 159	40132-30 160	41295-08 108	44425-10 55	47191-03 119
40021-30 159	40140-17 160	41295-09 108	45201-11 57	47191-04 119
40022-40 159	40141-20 160	41295-10 108	45206-14 57	47192-16 119
40023-50 159	40142-30 160	41295-11 108	45206-16 57	47195-01 119
40024-60 159	40150-20 160	41295-12 108	45208-14 57	47195-02 119
40030-30 159	40151-25 160	41297-06 108	47102-01 110	47197-01 119
40031-30 159	40152-30 160	41297-07 108	47102-02 110	47197-02 119
40032-40 159	40153-25 160	41297-08 108	47102-03 110	47223-01 120
40032-50 159	40154-30 160	41297-09 108	47103-01 111	47223-02 120
40034-60 159	40155-40 160	41297-10 108	47103-02 111	47223-03 120
40040-40 159	40156-25 160	41297-11 108	47103-03 111	47223-04 120
40041-50 159	40157-30 160	41297-12 108	47112-01 112	47223-05 120
40050-20 159	40158-40 160	41299-03 107	47112-02 112	47224-01 120
40051-30 159	40160-20 160	41299-05 107	47112-03 112	47224-02 120
40052-40 159	40161-25 160	41299-07 107	47116-13 112	47224-03 120
40053-20 159	40162-30 160	43150-11 58	47118-13 112	47224-04 120
40054-30 159	40163-25 160	43370-12 86	47120-35 113	47224-05 120
40055-30 159	40164-30 160	43372-13 86	47120-35CL. 113	47225-01 120
40056-40 159	40164-40 160	43373-13 86	47120-35S... 114	47225-02 120
40057-30 159	40166-25 160	43376-13 86	47120-50 113	47225-03 120
40058-50 159	40167-30 160	43377-13 86	47120-50CL. 113	47225-04 120
40060-30 159	40168-40 160	43378-13 86	47120-50S... 114	47226-01 120
40061-30 159	40170-30 161	43583-07 5	47120-75 113	47226-02 120
40070-60 159	40180-30 161	43583-18 5	47120-75CL. 113	47226-03 120
40071-60 159	40190-30 161	43810-10 52	47120-75S... 114	47227-01 120
40080-20 159	40191-40 161	43811-10 52	47120-90 113	47227-02 120
40081-20 159	40192-30 161	43813-10 52	47120-90CL. 113	47227-03 120
40090-20 159	40193-40 161	43820-10 52	47120-90S... 114	47237-01 121
40091-30 159	40200-30 161	43821-10 52	47124-35 115	47237-02 121
40092-40 159	40201-40 161	43823-10 52	47124-35CL. 115	47239-01 121
40093-30 159	40202-30 161	43940-05 53	47124-35S... 116	47239-02 121
40094-40 159	40203-40 161	43940-08 53	47124-50 115	47242-00 121
40095-50 159	40300-30 163	43942-05 53	47124-50CL. 115	47242-01 121
40096-50 159	40301-60 163	43942-08 53	47124-50S... 116	47251-21 122
40100-30 159	40302-40 163	43950-10 54	47124-75 115	47256-20 122
40110-17 160	40303-60 163	43952-10 54	47124-75CL. 115	47323-19 123
40111-20 160	40304-90 163	43953-10 54	47124-75S... 116	47325-19 123
40112-30 160	40400-40 163	44015-20 55	47124-90 115	47347-20 109
40113-20 160	40401-60 163	44015-27 55	47124-90CL. 115	47370-16 124
40114-17 160	40402-60 163	44076-05 56	47124-90S... 116	47371-16 124
40115-20 160	40500-30 163	44076-10 56	47151-15 57	47372-16 124
40116-30 160	40501-60 163	44078-05 56	47151-18 57	47373-16 124
40120-17 160	40502-60 163	44078-10 56	47154-20 57	47374-16 124
40121-20 160	41054-20 85	44150-01 55	47158-20 117	47375-16 124
40122-30 160	41056-18 85	44150-03 55	47159-20 117	47375-19 124
40123-20 160	41058-18 85	44150-05 55	47161-16 117	47376-16 124
40124-17 160	41068-20 85	44150-10 55	47161-20 117	47379-16 125

47380-15 125	47463-14 129	47523-02 134	49274-13 141	49623-16 148
47382-15 125	47470-04 127	47524-01 134	49274-15 141	49624-16 148
47384-15 125	47470-05 127	47525-20 134	49278-01 105	49627-01 148
47385-15 125	47470-06 127	47526-20 134	49278-02 105	49630-02 148
47386-01 125	47470-07 127	47530-00 138	49280-18 105	49635-18 149
47386-02 125	47471-02 127	47530-01 138	49281-01 106	49640-05 149
47390-03 126	47471-03 127	47530-02 138	49281-02 106	49640-07 149
47390-04 126	47471-04 127	47532-19 138	49310-00 142	49640-09 149
47390-05 126	47471-05 127	47533-19 138	49310-01 142	49650-06 149
47392-03 126	47471-06 127	47534-19 138	49310-02 142	49650-07 149
47392-04 126	47471-07 127	47535-01 139	49310-03 142	49650-09 149
47392-05 126	47471-08 127	47535-02 139	49310-04 142	49650-11 149
47410-04 102	47471-10 127	47538-01 87	49310-05 142	49660-18 150
47410-05 102	47471-12 127	47538-02 87	49310-09 142	49666-10 151
47411-16 102	47472-10 127	47538-03 87	49310-10 142	49666-15 151
47414-21 102	47472-12 127	47538-04 87	49310-11 142	49666-20 151
47415-18 102	47472-14 127	47540-16 87	49310-12 142	49667-10 151
47417-19 102	47472-16 127	47550-11 87	49315-00 143	49667-15 151
47419-19 102	47473-01 130	47550-11CL 87	49315-01 143	49680-10 150
47420-01 103	47473-02 130	47551-16 87	49315-02 143	49680-20 150
47420-02 103	47473-03 130	47551-16CL 87	49315-03 143	49685-21 150
47420-03 103	47474-01 130	47552-16 87	49315-10 143	49691-15 150
47420-04 103	47474-02 130	47553-15 87	49317-00 143	49692-15 150
47420-20 103	47474-03 130	47554-01 88	49317-01 143	49700-01 151
47421-21 103	47475-04 131	47554-02 88	49317-02 143	49700-02 151
47421-23 103	47475-06 131	47554-03 88	49317-03 143	55116-15 90
47422-22 103	47475-08 131	47555-08 88	49317-10 143	55117-17 90
47423-22 104	47481-05 130	47556-16 88	49320-00 144	55120-15 90
47424-16 104	47482-05 132	47557-17 88	49320-01 144	73193-30 5
47425-19 104	47484-04 132	47558-15 88	49320-02 144	93250-15T 95
47426-22 104	47484-06 132	47559-20 88	49320-03 144	93250-18T 95
47428-21 104	47484-08 132	47560-18 89	49320-10 144	93250-21T 95
47430-22 104	47486-16 132	47562-18 89	49320-20 144	93251-15T 95
47450-04 128	47487-16 132	47563-22 89	49340-00 144	93251-18T 95
47451-04 128	47489-16 132	47564-16 89	49342-01 145	93251-21T 95
47454-04 129	47502-16 134	47565-10 57	49342-02 145	93260-15T 95
47454-07 129	47504-18 134	47566-12 89	49342-03 145	93260-18T 95
47454-09 129	47507-17 134	47567-11 89	49342-04 145	93260-21T 95
47454-12 129	47507-18 134	47568-08 89	49342-05 145	93261-15T 95
47455-06 129	47511-21 135	47571-23 140	49605-07 146	93261-18T 95
47458-04 129	47513-21 135	47572-23 140	49605-10 146	93261-21T 95
47458-07 129	47514-16 135	47573-23 140	49605-11 146	93385-21 12
47458-09 129	47516-16 135	47575-23 140	49605-12 146	93385-25 12
47458-12 129	47518-21 135	49115-01 141	49605-14 146	93390-21 12
47460-04 129	47520-21 136	49115-01CL 141	49605-16 146	
47460-07 129	47522-01 137	49115-02 141	49610-12 147	
47460-12 129	47522-04 137	49115-02CL 141	49610-13 147	
47461-00 133	47522-05 137	49117-11 141	49610-16 147	
47462-00 133	47522-07 137	49257-20 122	49613-10 148	
47463-10 129	47522-09 137	49274-09 141	49615-12 148	
47463-12 129	47523-01 134	49274-11 141	49620-15 148	

A

ACKERMANN Markierungsinstrument 5

ADSON, Arterienklemme 64

ADSON, Durahaken 85

ADSON, Pinzette 38-39

ADSON, Saugrohr 107

ADSON-BROWN, Pinzette 40

AGRIS-DINGMAN, Brustdissektor 81

ALM, Wundhaken 75

Anatomische Pinzette 36

ANDERSON, Hauthäkchen 79

ANDREW, Zungenspatel 141

Antrumraspel, WIENER 134

Arterienklemme, ADSON 64

Arterienklemme, COLLER-CRILE 61

Arterienklemme, CRILE 62

Arterienklemme, CRILE-RANKIN 62

Arterienklemme, HALSTED-MOSQUITO 60

Arterienklemme, HARTMANN 59

Arterienklemme, JACOBSON Micro 60

Arterienklemme, KELLY 61

Arterienklemme, KELLY-RANKIN 61

Arterienklemme, LERICHE 63

Arterienklemme, PROVIDENCE-HOSPITAL 61

Arterienklemme, ROCHESTER-OCHSNER 63

Arterienklemme, ROCHESTER-PEAN 63

ASCH, Septumrichtzange 140

Atrauma Pinzette, DeBAKEY 47-48, 51

AUFRICHT, Nasenhaken 87

AUFRICHT, Nasenraspel 135

B

BABY OLSEN-HEGAR, Nadelhalter 93

BABY WEBSTER, Nadelhalter 91

BALLENGER, Schwingmesser 126

BALLENGER, Septumelevator 104

BARON, Saugrohr 107

BARRAQUER, Cilienpinzette 55

BARRAQUER, Nadelhalter 95

BARSKY, Hauthäkchen 71

BAUMGARTNER, Nadelhalter 92

BEASELEY BABCOCK, Pinzette 39

Beckenzirkel, COLLIER 5

BERKE, Muskelpinzette 55

BERRY, TC-Drahtzange 97

BEUSE, Face-Lift-Schere 31

BEYER, Hohlmeißelzange 98

BIGGS, Wundhaken 79

BISHOP-HARMAN, Irispinzette 53

BLAIR, Gaumenspalt-Elevator 106

Blepharoplastik Schere, GREENBERG-PAR 32

Blepharoplastik Schere, KAYE 32

BÖHLER, Hohlmeißelzange 98

BÖHLER, Knochensplitterzange 99

BOIES, Elevator 102

BONN, Schere 20

BONNEY, Pinzette 45

BREAST, Wundhaken 80

BROWN, Pinzette 41

BRUENINGS, Septumzange 119

Brustdissektor, AGRIS-DINGMAN 81

Brustdissektor, MacCOLLUM-DINGMAN 81

Brustdissektor, LOCKWOOD 82

Brustdissektor, REYNOLDS (Transauxillary) 81

Brustdissektor, SILVERSTEIN 82

Brustdissektor, TEBBETTS 81

Brustspatel 80

Bügel, McIVOR 144

C

CAPLAN, Nasenschere 122

CASTROVIEJO, Meßinstrument 5

CASTROVIEJO, Meßzirkel 5

CASTROVIEJO, Mikro-Nadelhalter 96

CASTROVIEJO, Nahtpinzette 55

CHADWICK, Zahnfleissschere 26

Chalazionspinzette, DESMARRES 55

Chirurgische Pinzette 37

Cilienpinzette, BARRAQUER 55

CINELLI, Septummeißel 127

COLLER-CRILE, Arterienklemme 61

COLLIER, Beckenzirkel 5

COLLIN-DUVAL, Fußpinzette 42

Columella-Pinzette, COTTLE 57

CONVERSE, Nasenhaken 87, 89

CONVERSE, Nasenmesser 125

CONVERSE/WILMER/WALTER, Schere 22

CORONAL, Wundhaken 84

COTTLE, Columella-Pinzette 57

COTTLE, Fixierpinzette 57

COTTLE, Hauthäkchen 88-89

COTTLE, Knorpelquetscher 133

COTTLE, Nasenhaken 87

COTTLE, Nasenmesser 125

COTTLE, Nasenschere 27

COTTLE, Nasenspekula 115-116

COTTLE, Osteotom 129

COTTLE, Schere 22

COTTLE, Septumelevator 103-104

COTTLE, Septummeißel 129

COTTLE, Septumosteotom 129

FOMON, Septumosteotom 127

SHEEHAN, Septumosteotom 127

COTTLE, Stahlhammer 100

COTTLE-JOSEPH, Septumelevator 103

COTTLE-KAZANJIAN, Knochensplitterzange 99

COTTLE-MASING, Nasenschere 27

COTTLE-NEIVERT, Hauthäkchen 88

CRAIG, Septumzange 119

CRILE, Arterienklemme 62

CRILE, Nervhaken 85

CRILE, Wundhaken 65

CRILE-RANKIN, Arterienklemme 62

CRILE-WOOD, Nadelhalter 92

CRONIN, Gaumenspalt-Messer 105

CUSHING (TAYLOR), Pinzette 44

CUSHING, Nervenhaken 85

CUSHING, Pinzette 41

D

Darmspatel, RIBBON 66

D'ASSUMPCAO, Markierungsinstrument 3

Daumenhäkchen, MILLARD 84

DAVIS-BOYLE, Mundsperrer 142

DAVIS-BOYLE, Zungenspatel 142

DAVIS-MEYER, Mundsperrer 144

DEAVER, Wundhaken 67-68

DeBAKEY, Atrauma Pinzette 49-51

DeBAKEY, Nadelhalter 92

Delphinzange für plastische Endoskopie 157

DERF, Nadelhalter 91

Dermatom, HUMBY 7

Dermatom, SCHINK 6

Dermatom, SILVER 7

Dermatom, WATSON 7

DESMARRES, Chalazionspinzette 55

DESMARRES, Wundhaken 73

DINGMANN, Elevator 150

DINGMANN, Mundsperrer 143

DINGMANN, Nasenraspel.....138
 DINGMANN, Raspator150
 DINGMANN, Sperrer.....143
 DINGMANN, Zungenspatel143
 Dissektor, GORNEY102
 Drahtbürste138
 Drahtzange TC, BERRY97
 Drahtzange TC,
 MAYO-HABERISSER.....97
 Durahaken, ADSON85
 DURANTE, Faßpinzette45
 DUVAL, Faßpinzette42

E

Elevator, BALLENGER.....104
 Elevator, BOIES.....102
 Elevator, COTTLE-JOSEPH..... 103-104
 Elevator, DINGMANN.....150
 Elevator, FREER102
 Elevator, HAJEK-BALLENGER104
 Elevator, HOWARTH.....103
 Elevator, JOSEPH102
 Elevator, KILLIAN 103-104
 Elevator, MASING102
 Elevator, MCKENTY..... 102-103
 Elevator, OBWEGESER.....149
 Elevator, PENNINGTON.....103
 Elevator, PIERCE103
 Elevator, SINUS.....103
 Endo-Dissektor77
 Endo-Dissektor, LANGENBECK.....77
 Endo-Dissektor,
 MINI-LANGENBECK77
 Endoskop.....152
 Ersatzbacken f. Hammer100
 Ersatzklinge f. SCHINK Dermatome.....6
 Ersatzklingen f. Dermatom7

F

Face-Lift-Schere, BEUSE.....31
 Face-Lift-Schere, GORNEY30
 Face-Lift-Schere,
 GORNEY-FREEMAN30
 Face-Lift-Schere, KAYE.....31
 Face-Lift-Schere, PECK-JOSEPH.....31
 Fadenpinzette, OCHSNER.....45
 Fadenschere, LITTAUER28
 Fadenschere, O'BRIEN28
 Fadenschere, SPENCER28
 FARABEUF, Wundhaken.....65
 Faßpinzette, COLLIN-DUVAL.....42

Faßpinzette, DURANTE45
 Faßpinzette, DUVAL.....42
 Faßpinzette, RUSS. MODELL.....42
 Faßzange f. plastische
 Endoskopie.....157
 Faßzange, MARYLAND157
 FERRIERA, Wundhaken78
 FERRIS-SMITH, Pinzette42
 Finger-Goniometer2
 FINSEN, Wundhaken75
 Fixierpinzette, COTTLE.....57
 Fixierpinzette, GREEN56
 Flachmeißel, MINI-LAMBOTTE.....132
 FOMON, Hauthäkchen.....88
 FOMON, Nasenraspel136
 FOMON, Nasenschere.....27
 FOMON, Raspator.....101
 FOMON, Septummeißel.....127
 FRAZIER, Hauthäkchen.....70
 FRAZIER/FERGUSON,
 Saugrohr.....108
 FREEMAN,
 Markierungsinstrument.....4
 FREEMAN, Wundhaken.....68, 84
 FREER, Hauthäkchen88
 FREER, Mukosamesser.....124
 FREER, Septumlevator102
 FREER, Septumhohlmeißel132
 FREER, Septummeißel128
 FRIEDMANN, Hohlmeißelzange98

G

Gaumenspalt-Elevator, BLAIR.....106
 Gaumenspalter, Raspatorium105
 Gaumenspalt-Messer, CRIONIN105
 Gefäßpinzette, STILLE-BARRAYA.....45
 GERALD, Pinzette..... 43-44
 GERZOG, Hammer100
 Gewebefaßpinzette, SINGLEY.....45
 GILLIES, Hauthäkchen.....89
 GILLIES, Nadelhalter94
 GILLIES, Pinzetten43
 GLABELLA, Nasenraspel134
 GOLDMAN-FOX, Zahnfleischschere..29
 Goniometer, Finger.....2
 GORNEY, Dissektor102
 GORNEY, Face-Lift-Schere.....30
 GORNEY Nasenschere.....122
 GORNEY, Wundhaken84
 GORNEY-FREEMAN,
 Face-Lift-Schere30

GRADLE, Schere23
 GRAEFE, Hauthäkchen.....69
 GRAEFE, Irispinzette52
 GRAEFE, Pinzette.....41
 GRAEFE, Schere22
 GREEN, Fixierpinzette56
 GREENBERG-PAR, Blepharoplastik
 Schere32
 GROSSMAN,
 Markierungsinstrument.....4
 GUILLEN, Saugraspatorium.....109
 GUTHRIE, Hauthäkchen69

H

HAJEK, Septumhohlmeißel132
 HAJEK-BALLENGER,
 Septumlevator104
 Hakenschere für plastische
 Endoskopie.....156
 HALPREN Markierungsinstrument.....5
 HALSEY, Nadelhalter91
 HALSTED-MOSQUITO,
 Arterienklemme60
 Hammer100
 Hammer, COTTLE.....100
 Hammer, GERZOG100
 Hammer, MEAD.....100
 Hammer, PARTSCH.....100
 Hammer, QUISLING.....100
 HARTMANN, Arterienklemme59
 HARTMANN, Nasenspekula111
 HARTMANN, Polypenzange117
 HARTMANN-HALLE,
 Nasenspekula110
 Hauthäkchen, FRAZIER70
 Hauthäkchen, ANDERSON84
 Hauthäkchen, BARSKY71
 Hauthäkchen, COTTLE 88-89
 Hauthäkchen, COTTLE-NEIVERT88
 Hauthäkchen, FOMON.....88
 Hauthäkchen, FREER88
 Hauthäkchen, GILLIES.....89
 Hauthäkchen, GRAEFE.....69
 Hauthäkchen, GUTHRIE69
 Hauthäkchen, HUMBY71
 Hauthäkchen, JOSEPH.....70
 Hauthäkchen, KLEINERT-KUTZ70
 Hauthäkchen, REDA.....72
 Hauthäkchen, TYRELL.....69
 HEYMANN, Nasenschere27

HEYMANN-KNIGHT, Polypenzange	118
Hohlmeißel, FREER	132
Hohlmeißel, HAJEK	132
Hohlmeißel, KILLIAN	130
Hohlmeißel, KILLIAN-CLAUS	132
Hohlmeißel, WEST	132
Hohlmeißelzange, BEYER	98
Hohlmeißelzange, BÖHLER	98
Hohlmeißelzange, FRIEDMANN	98
HOLZHEIMER, Wundsperrer	75
HOWARTH, Septumelevator	103
HUMBY, Dermatom	7
HUMBY, Hauthäkchen	71

I

IRIS, Schere	20
Irishäkchen, O'CONNOR	86
Irishäkchen, WIENER	86
Irispinzette, BISHOP-HARMAN	53
Irispinzette, GRAEFE	52

J

JACKSON, Trachealhaken	90
JACOBSON Mikro, Arterienklemme	60
JAEGER, Lidplatte	58
JAMESON, Präparierschere	19
JANSEN, Wundsperrer	75
JANSEN-GRUENWALD, Ohrpinzette	57
JENNINGS, Mundsperrer	141
J-Haken Elektrode, monopolar	158
JOSEPH (LEWIS), Nasenraspel	135
JOSEPH, Hauthäkchen	70
JOSEPH, Nasenmesser	124-125
JOSEPH, Nasenraspel	134
JOSEPH, Nasensäge	138-139
JOSEPH, Präparierschere	18
JOSEPH, Raspator	101
JOSEPH, Septumelevator	102
JOST, Knorpelquetscher	133

K

KASDEN, Wundhaken	73
KAYE, Blepharoplastik-Schere	32
KAYE, Face-Lift-Schere	31
KELLY, Arterienklemme	61
KELLY, Präparierschere	19
KELLY-RANKIN, Arterieklemme	61
KILLIAN, Hohlmeißel	130
KILLIAN, Nasenspekula	113-114

KILLIAN, Septumelevator	103-104
KILLIAN-CLAUS, Septumhohlmeißel	132
KILNER, Nasenhaken	88
KILNER, Präparierschere	19
KILNER-DOUGHTY, Mundsperrer	143
KILNER-DOUGHTY, Zungenspatel	143
KLAPP, Wundhaken	72
KLEINERT-KUTZ, Hauthäkchen	70
KNAPP, Schere	21
KNAPP, Tränensackhäkchen	86
KNIGHT, Septumzange	118
Knochensplitterzange, BÖHLER	99
Knochensplitterzange, COTTLE-KAZANJIAN	99
Knochensplitterzange, McINDOE	99
Knorpelquetscher, COTTLE	133
Knorpelquetscher, JOST	133
Knorpelschere, McINDOE	29
Knüpfpinzette, Mikro	47

L

LA GRANGE, Zahnfleissschere	26
LAHEY, Wundhäkchen	70
LANDOLT, Skalpellgriff	12
LANGE, Nasenflügelhäkchen	89
LANGENBECK, Endo-Dissektor	77
LANGENBECK, Raspator	101
LERCHE, Pinzette	41
LERICHE, Arterienklemme	63
LEXER BABY, Präparierschere	15
LEXER, Präparierschere	15
Lidplatte, JAEGER	58
Liposuction-Kanülen	159 -163
LITTAUER, Fadenschere	28
LITTLER, Schere	22
LOCKWOOD, Brustdissektor	82
LOCKWOOD, Markierungsinstrument	3
LUBET-BARBON, Nasentamponzange	117
LUC, Septumzange	119
LUCAE, Ohrpinzette	57

M

MacCOLLUM-DINGMAN, Brustdissektor	81
MALINIAC, Nasenhaken	87
MALTZ (COTTLE), Nasenraspel	135
MALTZ, Nasenraspel	134

Markierungsinstrument, ACKERMANN	5
Markierungsinstrument, D'ASSUMPCAO	3
Markierungsinstrument, FREEMAN	4
Markierungsinstrument, GROSSMAN	4
Markierungsinstrument, HALPREN	5
Markierungsinstrument, LOCKWOOD	3
Markierungsinstrument, MCKISSOCK	5
Markierungsinstrument, PITANGUY	3
MARTINEZ-KILNER, Wundhaken	89
MARYLAND, Faßzange für plastische Endoskopie	157
MASING, Elevator	102
MASING-NEIVERT, Nasenhaken	87
Maßstab, Metall	2
MAYO, Präparierschere	13
MAYO-HABERISSER, TC-Drahtzange	97
MAYO-HEGAR, Nadelhalter	92
MAYO-STILLE, Präparierschere	14
McINDOE, Knochensplitterzange	99
McINDOE, Knorpelschere	29
McINDOE, Pinzetten	42
McIVOR, Mundsperrer	144
McIVOR, Bügel	144
McIVOR, Zungenspatel	144
MCKENTY, Septumelevator	102-103
MCKISSOCK, Markierungsinstrument	5
MEAD, Hammer	100
Meißel, CINELLI	127
Meißel, COTTLE	129
Meißel, FREER	128
Meißel, KILLIAN	130
Meißel, MINI-LAMBOTTE	132
Meißel, SILVER	130
Meßinstrument, CASTROVIEJO	5-6
Meßinstrument, COLLIER	5
Meßzirkel, CASTROVIEJO	5
Metallmaßstab	2
METZENBAUM, Präparierschere	16-17
METZENBAUM, Schere für plastische Endoskopie	156
METZENBAUM-FINO, Präparierschere	17
MEYERDING, Wundhaken	74
Micro HARTMANN, Arterienklemme	59
MICROVASCULAR, Nadelhalter	93
MIDDLETON-JANSEN, Septumzange	123

Mikro Knüpfpinzette.....	47
Mikro Nadelhalter, CASTROVIEJO	96
Mikro Pinzette.....	43
Mikro Ringpinzetten.....	48
Mikro Schere	33-35
MILLARD, Daumenhäkchen.....	84
MILLER, Wundhäkchen	86
MINI, Skalpellgriff	11
MINI, Skalpellklingen.....	11
MINI-LAMBOTTE, Flachmeißel.....	132
MINI-LANGENBECK, Endo-Dissektor	77
Mobilisierhaken, TESSIER	150
MOD. BONN, Nahtpinzette.....	54
MOD. WIEN, Nasenspekula	112
MOD.TUEBINGEN, Nahtpinzette	54
MOELTGEN, Winkelmesser	2
Monopolare J-Haken-Elektrode.....	158
Monopolare Spatel-Elektrode	158
Mukosamesser, FREER.....	124
Mundsperrerr, DAVIS-BOYLE.....	142
Mundsperrerr, DAVIS-MEYER.....	144
Mundsperrerr, DINGMANN.....	143
Mundsperrerr, JENNINGS	141
Mundsperrerr, KILNER-DOUGHTY	143
Mundsperrerr, McIVOR.....	144
Muskelpinzette, BERKE	55
MYLES, Nasenzange	121

N

Nadelhalter, BABY OLSEN-HEGAR.....	93
Nadelhalter, BABY WEBSTER	91
Nadelhalter, BARRAQUER.....	95
Nadelhalter, BAUMGARTNER	92
Nadelhalter, CRILE-WOOD	92
Nadelhalter, DeBAKEY	92
Nadelhalter, DERF.....	91
Nadelhalter, GILLIES.....	94
Nadelhalter, HALSEY	91
Nadelhalter, MAYO-HEGAR	92
Nadelhalter, MICROVASCULAR	93
Nadelhalter, Mikro, Titan.....	95
Nadelhalter, OLSEN-HEGAR	93
Nadelhalter, RYDER.....	93
Nadelhalter, WEBSTER.....	91
Nahtpinzette, CASTROVIEJO	55
Nahtpinzette, MOD. BONN.....	54
Nahtpinzette, MOD. TUEBINGEN	54
Nasenflügelhäkchen, LANGE.....	89
Nasenhaken, AUFRICHT	87
Nasenhaken, CONVERSE	87, 89

Nasenhaken, COTTLE	87
Nasenhaken, KILNER	88
Nasenhaken, MALINIAC	87
Nasenhaken, MASING-NEIVERT	87
Nasennmesser, CONVERSE	125
Nasennmesser, COTTLE	125
Nasennmesser, JOSEPH	124-125
Nasennraspel, AUFRICHT	135
Nasennraspel, DINGMAN	138
Nasennraspel, FOMON	136-137
Nasennraspel, GLABELLA.....	134
Nasennraspel, JOSEPH.....	134
Nasennraspel, JOSEPH (LEWIS)	135
Nasennraspel, MALTZ.....	134
Nasennraspel, MALTZ (COTTLE)	135
Nasennraspel, PARKES	134
Nasennraspel, PEET	134
Nasensäge, JOSEPH.....	138-139
Nasenschere, CAPLAN.....	122
Nasenschere, COTTLE	27
Nasenschere, COTTLE-MASING.....	27
Nasenschere, FOMON.....	27
Nasenschere, GORNEY.....	122
Nasenschere, HEYMANN	27
Nasenspekula, COTTLE.....	115-116
Nasenspekula, HARTMANN	111
Nasenspekula, HARTMANN-HALLE.....	110
Nasenspekula, KILLIAN	113-114
Nasenspekula, Mod. WIEN	112
Nasenspekula, REDA.....	112
Nasenspekula, TIECK-HALLE.....	112
Nasentamponzange, LUBET-BARBON.....	117
Nasentamponzange, WESTMACOTT.....	117
Nasenzange, MYLES	121
Nasenzange, SCHMEDEN.....	121
Nasenzange, TAKAHASHI	121
Nasenzange, WEIL-BLAKESLEY.....	120
NEIVERT-ANDERSON, Osteotom.....	130
Nervhaken	77
Nervhaken, CRILE.....	85
Nervhaken, CUSHING.....	85
NEWS, Trachealhaken	90

O

O'BRIEN, Fadenschere	28
OBWEGESER, Osteotom	131
OBWEGESER, Raspator	149
OBWEGESER, Wundhaken.....	146-148

OCHSNER, Fadenpinzette.....	45
O'CONNOR, Irishäkchen.....	86
OEHLER, chirurgische Pinzette	37
Ohrpinzette, JANSEN-GRUENWALD	57
Ohrpinzette, LUCAE	57
Ohrpinzette, TROELTSCH	57
Ohrpinzette, WILDE (TROELTSCH).....	57
OLSEN-HEGAR, Nadelhalter	93
Ophthalmologie Schere	23
Optik f. plastische Endoskopie	152
Osteotom	151
Osteotom, CINELLI	127
Osteotom, COTTLE.....	129
Osteotom, FOMON.....	127
Osteotom, NEIVERT-ANDERSON	130
Osteotom, OBWEGESER	131
Osteotom, RUBIN.....	129
Osteotom, SHEEHAN.....	127
Osteotom, TESSIER.....	151
Osteotom, WEST.....	132

P

PARKES, Nasennraspel	134
PARTSCH, Hammer	100
PECK-JOSEPH, Face-Lift-Schere.....	31
PEET, Nasennraspel	134
PENNINGTON, Septumlevator	103
PIERCE, Septumlevator	103
Pinzette, CUSHING (TAYLOR).....	44
Pinzette, ADSON	38-39
Pinzette, ADSON-BROWN	40
Pinzette, anatomisch	36
Pinzette, BARRAQUER.....	55
Pinzette, BEASELEY BABCOCK	39
Pinzette, BERKE	55
Pinzette, BISHOP-HARMAN	53
Pinzette, BONNEY	45
Pinzette, BROWN.....	41
Pinzette, CASTROVIEJO	55
Pinzette, chirurgisch	37
Pinzette, COLLIN-DUVAL.....	42
Pinzette, COTTLE	57
Pinzette, CUSHING	41
Pinzette, DeBAKEY	48-51
Pinzette, DESMARRES.....	55
Pinzette, DURANTE	45
Pinzette, DUVAL	42
Pinzette, FERRIS-SMITH	42
Pinzette, GERALD.....	43-44
Pinzette, GILLIES.....	43

Pinzette, GRAEFE.....	41, 52
Pinzette, GREEN.....	56
Pinzette, JANSEN-GRUENWALD.....	57
Pinzette, LERCHE.....	41
Pinzette, LUCAE.....	57
Pinzette, McINDOE.....	42
Pinzette, MOD. BONN.....	54
Pinzette, MOD. TUEBINGEN.....	54
Pinzette, OCHSNER.....	45
Pinzette, OEHLER.....	37
Pinzette, POTTS-SMITH.....	36
Pinzette, RUSS. MODELL.....	42
Pinzette, SEMKEN.....	43
Pinzette, SINGLEY.....	45
Pinzette, STILLE.....	36-37
Pinzette, STILLE-BARRAYA.....	45
Pinzette, TAYLOR.....	44
Pinzette, TROELTSCH.....	57
Pinzette, USA.....	36-37
Pinzette, WAUGH.....	41
Pinzette, WILDE (TROELTSCH).....	57
PITANGUY, Markierungsinstrument.....	3
Polypenzange, HARTMANN.....	117
Polypenzange, HEYMANN-KNIGHT.....	118
POTTS-SMITH, Pinzette.....	36
Präparierschere, JAMESON.....	19
Präparierschere, JOSEPH.....	18
Präparierschere, KELLY.....	19
Präparierschere, KILNER.....	19
Präparierschere, LEXER.....	15
Präparierschere, LEXER BABY.....	15
Präparierschere, MAYO.....	13
Präparierschere, MAYO-STILLE.....	14
Präparierschere, METZENBAUM.....	16-17
Präparierschere, METZENBAUM FINO.....	17
Präparierschere, RAGNELL.....	19
Präparierschere, REYNOLDS.....	19
Präparierschere, SANVENERO.....	18
PROVIDENCE-HOSPITAL, Arterienklemme.....	61

Q

QUISLING, Hammer.....	100
-----------------------	-----

R

RAGNELL, Präparierschere.....	19
RAGNELL, Wundhaken.....	65
RAMUS, Wundhaken.....	148

Rasierklingen, unsteril.....	7
Raspator, DINGMANN.....	150
Raspator, FOMON.....	101
Raspator, JOSEPH.....	101
Raspator, LANGENBECK.....	101
Raspator, OBWEGESER.....	149
Raspator, WILLIGER.....	101
Raspatorium, Gaumenspalter.....	105
Raspel, AUFRICHT.....	135
Raspel, DINGMAN.....	138
Raspel, FOMON.....	136-137
Raspel, JOSEPH (LEWIS).....	135
Raspel, MALTZ (COTTLE).....	135
Raspel, PARKES.....	134
Raspel, PEET.....	134
Raspel, WIENER.....	134
REDA, Hauthäkchen.....	72
REDA, Nasenspekula.....	112
REDA, Sichelmesser.....	125
REYNOLDS, Präparierschere.....	19
REYNOLDS, (Transauxillary) Brustdissektoren.....	81-82
RIBBON, Darmspatel.....	66
Ringpinzette, Mikro.....	49
ROCHESTER-OCHSNER, Arterienklemme.....	63
ROCHESTER-PEAN, Arterienklemme.....	63
ROLLET, Tränensackhäkchen.....	86
ROUX MINI, Wundhaken.....	65
RUBIN, Osteotom.....	129
RUBIN, Septumzange.....	122
RUSS. MODELL, Faßpinzette.....	42
RUSSEL-DAVIS, Zungenspatel.....	145
RYDER, Nadelhalter.....	93

S

SANVENERO, Präparierschere.....	18
Saugraspatorium, GUILLEN.....	109
Saugrohr, ADSON.....	107
Saugrohr, BARON.....	107
Saugrohr, FRAZIER/FERGUSSON.....	108
Schaft f. plastische Endoskopie.....	80, 153-155
Schere f. plastische Endoskopie.....	156
Schere, BEUSE.....	31
Schere, BONN.....	20
Schere, CHADWICK.....	26
Schere, CONVERRSE/WILMER.....	22
Schere, COTTLE.....	22, 27
Schere, COTTLE-MASING.....	27

Schere, FOMON.....	27
Schere, GOLDMAN-FOX.....	29
Schere, GORNEY.....	30
Schere, GORNEY-FREEMAN.....	30
Schere, GRADLE.....	23
Schere, GRAEFE.....	22
Schere, GREENBERG-PAR.....	32
Schere, HEYMANN.....	27
Schere, IRIS.....	20
Schere, JAMESON.....	19
Schere, JOSEPH.....	18
Schere, KAYE.....	31-32
Schere, KELLY.....	19
Schere, KILNER.....	19
Schere, KNAPP.....	21
Schere, LA GRANGE.....	26
Schere, LEXER.....	15
Schere, LEXER BABY.....	15
Schere, LITTAUER.....	28
Schere, LITTLER.....	22
Schere, MAYO.....	13
Schere, MAYO-STILLE.....	14
Schere, McINDOE.....	29
Schere, METZENBAUM.....	16-17
Schere, METZENBAUM-FINO.....	17
Schere, Mikro.....	33-35
Schere, O'BRIEN.....	28
Schere, Ophthalmologie.....	23
Schere, PECK-JOSEPH.....	31
Schere, RAGNELL.....	19
Schere, REYNOLDS.....	19
Schere, SANVENERO.....	18
Schere, SPENCER.....	28
Schere, STEVENS.....	24
Schere, STRABISMUS.....	24
Schere, WAGNER.....	25
SCHINK, Dermatom.....	6
SCHMEDEN, Nasenzange.....	121
Schwingmesser, BALLENGER.....	126
SCULPO Wundhaken mit Schaft f. Endoskopie.....	79
SEMKEN, Pinzetten.....	43
Septumlevator, BALLENGER.....	104
Septumlevator, COTTLE.....	103-104
Septumlevator, COTTLE-JOSEPH.....	103
Septumlevator, FREER.....	102
Septumlevator, HAJEK-BALLENGER.....	104
Septumlevator, HOWARTH.....	103
Septumlevator, JOSEPH.....	102

Septumelevator, KILLIAN	103-104
Septumelevator, McKENTY	102-103
Septumelevator, PENNINGTON	103
Septumelevator, PIERCE	103
Septumelevator, SINUS	103
Septumhohlmeißel, FOMON	127
Septumhohlmeißel, FREER	132
Septumhohlmeißel, HAJEK	132
Septumhohlmeißel, KILLIAN-CLAUS	132
Septummeißel, CINELLI	127
Septummeißel, COTTLE	129
Septummeißel, FREER	128
Septummeißel, SHEEHAN	127
Septummeißel, SILVER	130
Septumosteotom, COTTLE	129
Septumrichtzange, ASCH	140
Septumrichtzange, WALSHAM	140
Septumzange, BRUENINGS	119
Septumzange, CRAIG	119
Septumzange, KNIGHT	118
Septumzange, LUC	119
Septumzange, MIDDLETON-JANSEN	123
Septumzange, RUBIN	122
Sichelmesser, REDA	125
Silikon-Schlauch	144
SILVER, Dermatom	7
SILVER, Septummeißel	130
SILVERSTEIN, Brustdissektor	82
SINGLEY, Gewebefäßpinzette	45
SINUS, Septumelevator	103
Skalpellgriff, LANDOLT	12
Skalpellgriff, Mini	11
Skalpellklingen, Mini	11
Spannplatte	6
Spatel	80
Spatel-Elektrode, monopolar	158
SPENCER, Fadenschere	28
Sperrer, DAVIS-BOYLE	142
Sperrer, DINGMANN	143
Sperrer, KILNER-DOUGHTY	143
SPINA-NASALIS, Wundhaken	148
Splitterpinzetten	46
Stahlhammer, COTTLE	100
STEVENS, Schere	24
STILLE, Pinzette	36-37
STILLE-BARRAYA, Gefäßpinzette	45
STRABISMUS, Schere	24
STRANDELL-STILLE, Wundhaken	74

T

TAKAHASHI, Nasenzange	121
Tamponzange, LUBET-BARBON	117
Tamponzange, WESTMACOTT	117
TAYLOR, Pinzette	44
TC-Drahtzange, BERRY	97
TC-Drahtzange, MAYO-HABERISSER	97
TC-Nasenraspel, FOMON	137
TC-Nasenraspel, MALTZ (COTTLE)	135
TEBBETTS, Brustdissektor	81
TEBBETTS, Wundhaken	78
TESSIER, Mobilisierhaken	150
TESSIER, Osteotom	151
TIECK-HALLE, Nasenspekula	112
Titan Mikro Nadelhalter	95-96
Trachealhaken, JACKSON	90
Trachealhaken, NEWS	90
Tränensackhäkchen, KNAPP	86
Tränensackhäkchen, ROLLET	86
TROELTSCH, Ohrpinzette	57
TYRELL, Hauthäkchen	69

U

Uhrmacherpinzette	46
USA, Pinzette	36-37

V

VOLKMANN, Wundhaken	73
---------------------------	----

W

WAGNER, Schere	25
WALSHAM, Septumrichtzange	140
WALTER/CONVERSE/WILMER, Schere	22
WATSON, Dermatom	7
WAUGH, Pinzette	41
WEBSTER, Nadelhalter	91
WEIL-BLAKESLEY, Nasenzange	120
WEITLANER, Wundsprerrer	76
WEST, Hohlmeißel	132
WEST, Osteotom	132
WESTMACOTT, Nasentamponzange	117
WIEDER, Zungenspatel	141
WIENER, Antrumraspel	134
WIENER, Irishäkchen	86
WILDE (TROELTSCH), Ohrpinzette	57

WILLIGER, Raspator	101
WILMER/CONVERSE/WALTER, Schere	22
Winkelmesser, MOELTGEN	2
Wundhäkchen, BARSKY	71
Wundhäkchen, COTTLE	88-89
Wundhäkchen, COTTLE-NEIVERT	88
Wundhäkchen, FOMON	88
Wundhäkchen, FREER	88
Wundhäkchen, GILLIES	89
Wundhäkchen, HUMBY	71
Wundhäkchen, KNAPP	86
Wundhäkchen, LAHEY	70
Wundhäkchen, MILLER	86
Wundhäkchen, O'CONNOR	86
Wundhäkchen, ROLLET	86
Wundhäkchen, WIENER	86
Wundhaken	150
Wundhaken für plastische Chirurgie	78-81
Wundhaken mit Schaft f. Endoskopie, SCULPO	79
Wundhaken, ALM	75
Wundhaken, ANDERSON	84
Wundhaken, BIGGS	79
Wundhaken, BREAST	80
Wundhaken, CORONAL	84
Wundhaken, CRILE	65
Wundhaken, DEAVER	67-68
Wundhaken, DESMARRES	73
Wundhaken, FARABEUF	65
Wundhaken, FERRIERA	78
Wundhaken, FINSSEN	75
Wundhaken, FREEMAN	68, 84
Wundhaken, GORNEY	84
Wundhaken, KASDEN	73
Wundhaken, KLAPP	72
Wundhaken, MARTINEZ-KILNER	89
Wundhaken, MEYERDING	74
Wundhaken, OBWEGESER	146-148
Wundhaken, RAGNELL	65
Wundhaken, RAMUS	148
Wundhaken, ROUX MINI	65
Wundhaken, SPINA-NASALIS	148
Wundhaken, STRANDELL-STILLE	74
Wundhaken, TEBBETTS	78
Wundhaken, VOLKMANN	73
Wundhaken, YANCOSKIE	83
Wundsperrer, HOLZHEIMER	75
Wundsprerrer, JANSEN	75
Wundsprerrer, WEITLANER	76

Y

YANCOSKIE, Wundhaken.....83

Z

Zahnfleischschere, CHADWICK.....26

Zahnfleischschere,
GOLDMAN-FOX.....29

Zahnfleischschere, LA GRANGE.....26

Zungenspatel, ANDREW141

Zungenspatel, DAVIS-BOYLE142

Zungenspatel, DINGMANN143

Zungenspatel, KILNER-DOUGHTY...143

Zungenspatel, McIVOR144

Zungenspatel, RUSSEL-DAVIS.....145

Zungenspatel, WIEDER141

A

ACKERMANN marker	5
ADSON, dressing forceps	38
ADSON, forceps	64
ADSON, hook	85
ADSON, suction tube	107
ADSON, tissue forceps	38-39
ADSON-BROWN, tissue forceps	40
ADSON-DeBAKEY, dressing forceps	38
AGRIS-DINGMAN, dissector	81
ALM, retractor	75
ANDERSON, retractor	84
ANDREW, tongue depressor	141
ASCH, septum straightening forceps	140
Atrauma forceps, DeBAKEY	49-51
AUFRIEHT, nasal rasp	135
AUFRIEHT, retractor	87

B

BABY OLSEN-HEGAR, needle holder	93
BALLENGER, elevator	104
BALLENGER, knife	126
BARON, suction tube	107
BARRAQUER, cilia forceps	55
BARRAQUER, needle holder	95
BARSKY, retractor	71
BAUMGARTNER, needle holder	92
BEASELEY BABCOCK, Tissue forceps	39
BERKE, muscle forceps	55
BERRY, wire twisting forceps	97
BEUSE, scissors	31
BEYER, rongeur	98
BIGGS, retractor	79
BISHOP-HARMAN, iris forceps	53
BLAIR, lip and cleft palate Instrument	106
BÖHLER, bone cutting forceps	99
BÖHLER, rongeur	98
BOIES, elevator	102
Bone cutting forceps, BÖHLER	99
Bone cutting forceps, COTTLE-KAZANJIAN	99
Bone cutting forceps, MC INDOE	99
BONN, scissors	20
BONNEY, tissue forceps	45
Breast Dissectors, LOCKWOOD	82

Breast Dissector, REYNOLDS (Transauxillary)	81
BREAST, retractor	80
Breast, spatula	80
BROWN, tissue forceps	41
BRUENINGS, septum forceps	119

C

Caliper, CASTROVIEJO	5
CAPLAN, nasal cutting scissors	122
Cartilage crusher, COTTLE	133
Cartilage crusher, JOST	133
CASTROVIEJO, caliper	5
CASTROVIEJO, needle holder	96
CASTROVIEJO, suture forceps	55
CHADWICK, scissors	26
Chalazion forceps, DESMARRES	55
Chisel, CINELLI	127
Chisel, COTTLE	129
Chisel, FREER	128
Chisel, SHEEHAN	127
Chisel, WEST	132
Cilia forceps, BARRAQUER	55
COLLER-CRILE, forceps	61
COLLIER, pelvimeter	5
COLLIN-DUVAL, tissue forceps	42
Columella forceps, COTTLE	57
CONVERSE, knife	125
CONVERSE, retractor	87
CONVERSE, retractor	89
CONVERSE/WILMER/WALTER, Scissors	22
CORONAL, retractor	84
COTTLE JOSEPH, elevator	103
COTTLE, cartilage crusher	133
COTTLE, chisel	129
COTTLE, columella forceps	57
COTTLE, ear forceps	57
COTTLE, elevator	103-104
COTTLE, knife	125
COTTLE, mallet	100
COTTLE, nasal specula	115-116
COTTLE, osteotome	129
COTTLE, retractor	87-89
COTTLE, scissors	22, 27
COTTLE-KAZANJIAN, Bone Cutting forceps	99
COTTLE-MASING, scissors	27
COTTLE-NEIVERT, retractor	88
CRAIG, septum forceps	119
CRILE, forceps	62

CRILE, hook	85
CRILE, retractor	65
CRILE-RANKIN, forceps	62
CRILE-WOOD, needle holder	92
CRONIN, lip and cleft palate instrument	105
CUSHING, hook	85
CUSHING, tissue forceps	41
CUSHING-TAYLOR, Dressing Forceps	44

D

D'ASSUMPCAO, facelift marker	3
DAVIS-BOYLE, mouth gag	142
DAVIS-MEYER, mouth gag	144
DEAVER, retractor	67-68
DeBAKEY, atrauma forceps	49-51
DeBAKEY, needle holder	92
DERF, needle holder	91
Dermatome, HUMBY	7
Dermatome, SCHINK	6
Dermatome, SILVER	7
Dermatome, WATSON	7
DESMARRES, chalazion forceps	55
DESMARRES, retractor	73
DINGMAN, nasal rasp	138
DINGMANN, elevator	150
DINGMANN, mouth gag	143
Dissector, AGRIS-DINGMAN	81
Dissector, GORNEY	102
Dissector, LANGENBECK	77
Dissector, LANGENBECK-COTTLE	77
Dissector, MacCOLLUM-DINGMAN	81
Dissector, MINI-LANGENBECK	77
Dissector, SILVERSTEIN	82
Dissector, TEBBETTS	81
DOLPHIN, endoscopic grasper	157
Dressing forceps, ADSON	38
Dressing forceps, ADSON-DeBAKEY	38
Dressing forceps, CUSHING-TAYLOR	44
Dressing forceps, GERALD	43-44
Dressing forceps, McINDOE	42
Dressing forceps, OCHSNER	45
Dressing forceps, POTTS-SMITH	36
Dressing forceps, SEMKEN	43
Dressing forceps, SINGLEY	45
Dressing forceps, STILLE	36

Dressing forceps, TAYLOR.....44
 Dressing forceps, USA36
 Dressing, forceps..... 36-43
 DURANTE, tissue forceps45
 DUVAL, tissue forceps.....42

E

Ear forceps, COTTLE57
 Ear forceps,
 JANSEN-GRUENWALD57
 Ear forceps, LUCAE57
 Ear forceps, TROELTSCH.....57
 Ear forceps, WILDE (TROELTSCH).....
57
 Ear polypus forceps, HARTMANN
117
 Elevator, BALLENGER.....104
 Elevator, BOIES.....102
 Elevator, COTTLE 103-104
 Elevator, COTTLE JOSEPH103
 Elevator, DINGMANN150
 Elevator, FREER102
 Elevator, HAJEK-BALLENGER104
 Elevator, HOWARTH103
 Elevator, JOSEPH102
 Elevator, KILLIAN 103-104
 Elevator, LANGENBECK101
 Elevator, MASING102
 Elevator, McKENTY 102-103
 Elevator, OBWEGESER149
 Elevator, PENNINGTON.....103
 Elevator, PIERCE103
 Elevator, WILLIGER101
 Endoscope shaft, plastic surgery.....80,
 153-155
 Endoscope, plastic surgery153
 Endoscopic grasper, DOLPHIN157
 Endoscopic grasper, MARYLAND157
 Endoscopic scissors,
 METZENBAUM156
 Endoscopic, heavy grasper157
 Endoscopic, hook scissors156

F

Facelift marker, D'ASSUMPCAO.....3
 Facelift marker, LOCKWOOD.....3
 Facelift marker, PITANGUY3
 FARABEUF, retractor.....65
 FERRIERA, retractor.....78
 FERRIS-SMITH, tissue forceps.....42
 Finger, goniometer.....2

FINSEN, retractor75
 Fixation forceps, GREEN56
 FOMON septum chisels127
 FOMON, nasal rasp..... 136-137
 FOMON, nasal rasp.....137
 FOMON, raspatory101
 FOMON, retractor88
 FOMON, scissors27
 Forceps, ADSON64
 Forceps, COLLER-CRILE61
 Forceps, CRILE62
 Forceps, CRILE-RANKIN62
 Forceps, dressing 36-43
 Forceps, HALSTED-MOSQUITO60
 Forceps, HARTMANN59
 Forceps, KELLY.....61
 Forceps, KELLY-RANKIN61
 Forceps, LERICHE63
 Forceps, micro ring.....48
 Forceps, micro suture tying47
 Forceps, MICRO-HARTMANN59
 Forceps, PROVIDENCE-HOSPITAL
61
 Forceps, ROCHESTER-OCHSNER.....
63
 Forceps, ROCHESTER-PEAN63
 Forceps, splinter46
 Forceps, tissue 36-37
 FRAZIER/FERGUSON,
 suction tube108
 FREEMAN, marker.....4
 FREEMAN, retractor.....68, 84
 FREER, elevator.....102
 FREER, gouge132
 FREER, knife.....124
 FREER, retractor88
 FREER, rhinoplastic chisels128
 FRIEDMANN MINI, rongeur98
 FRIEDMANN, rongeur.....98

G

GERALD, dressing forceps 43-44
 GERALD, tissue forceps.....44
 GERZOG, mallet100
 GILLIES, needle holder94
 GILLIES, retractor.....89
 GILLIES, tissue forceps.....43
 GLABELLA, nasal rasp.....134
 GOLDMAN-FOX, scissors.....29
 Goniometer, finger.....2
 Goniometer, MOELTGEN2

GORNEY, dissector102
 GORNEY nasal cutting scissors.....122
 GORNEY, retractor84
 GORNEY, scissors30, 122
 GORNEY-FREEMAN, scissors30
 Gouge, FREER.....132
 Gouge, HAJEK132
 Gouge, KILLIAN130
 Gouge, KILLIAN-KLAUS132
 Gouge, WEST132
 GRADLE, scissors.....23
 GRAEFE, iris forceps52
 GRAEFE, retractor69
 GRAEFE, scissors.....22
 GRAEFE, tissue forceps.....41
 GREEN, fixation forceps.....56
 GREENBERG-PAR, scissors32
 GROSSMAN, marker4
 GUILLEN, suction tube.....109
 GUTHRIE, retractor69

H

HAJEK, gouge132
 HAJEK-BALLENGER, elevator104
 HALPREN marker5
 HALSEY, needle holder91
 HALSTED-MOSQUITO, forceps60
 Handles, scalpel 8-12
 HARTMANN, ear polypus forceps.....117
 HARTMANN, forceps59
 HARTMANN, nasal specula111
 HARTMANN-HALLE, nasal specula.....
110
 Heavy grasper, endoscopic157
 HEYMAN, scissors27
 HEYMANN-KNIGHT, nasal forceps...118
 HOLZHEIMER, retractor.....75
 Hook scissors, endoscopic156
 Hook, ADSON.....85
 Hook, CRILE.....85
 Hook, CUSHING.....85
 Hook, JACKSON90
 Hook, nerve77
 Hook, NEWS90
 Hook, thimble, MILLARD84
 HOWARTH, elevator103
 HUMBY, dermatome.....7
 HUMBY, retractor.....71

I

Iris forceps, BISHOP-HARMAN.....53
 Iris forceps, GRAEFE52
 IRIS, scissors.....20

J

JACKSON, hook.....90
 JAEGER, lid plate.....58
 JANSEN, retractor.....75
 JANSEN-GRUENWALD, ear forceps.....57
 JENNINGS, tongue depressor141
 J-Hook electrode, monopolar158
 JOSEPH (LEWIS), nasal rasp.....135
 JOSEPH, elevator102
 JOSEPH, knife.....124-125
 JOSEPH, nasal rasp.....134
 JOSEPH, nasal saw138-139
 JOSEPH, raspatory101
 JOSEPH, retractor.....70
 JOSEPH, scissors18
 JOST, cartilage crusher133

K

KASDAN, retractor73
 KAYE, scissors21, 32
 KELLY, forceps61
 KELLY, scissors19
 KELLY-RANKIN, forceps61
 KILLIAN, elevator103-104
 KILLIAN, gouge130
 KILLIAN, nasal specula113-114
 KILLIAN-KLAUS, gouge132
 KILNER, retractor88
 KILNER, scissors.....19
 KILNER-DOUGHTY, mouth gag.....143
 KLAPP, retractor.....72
 KLEINERT-KUTZ, retractor70
 KNAPP, retractor86
 KNAPP, scissors.....21
 Knife, BALLENGER.....126
 Knife, CONVERSE125
 Knife, COTTLE125
 Knife, FREER124
 Knife, JOSEPH.....124-125
 Knife, REDA.....125
 KNIGHT, nasal forceps.....118

L

LA GRANGE, scissors.....26

LAHEY, retractor.....70
 LANGE, retractor89
 LANGENBECK, dissector.....77
 LANGENBECK, elevator101
 LANGENBECK-COTTLE, dissector77
 LERCHE, tissue forceps.....41
 LERICHE, forceps63
 LEXER, scissors.....15
 LEXER-BABY, scissors15
 Liposuction cannulas.....159-163
 Lid plate, JAEGER.....58
 Lip and cleft palate instrument,105
 Lip and cleft palate instrument, BLAIR106
 Lip and cleft palate instrument, CRONIN105
 LITTAUER, scissors28
 LITTLER, scissors22
 LOCKWOOD, Breast Dissector.....82
 LOCKWOOD, facelift marker.....3
 LUBET-BARBON, nasal forceps117
 LUC, septum forceps.....119
 LUCAE, ear forceps.....57

M

MacCOLLUM-DINGMAN, dissector81
 MALINIAC, retractor87
 Mallet, COTTLE.....100
 Mallet, GERZOG100
 Mallet, MEAD.....100
 Mallet, nylon cap.....100
 Mallet, PARTSCH100
 Mallet, QUISLING.....100
 MALTZ (COTTLE), nasal rasp.....135
 MALTZ, nasal rasp134
 Marker, ACKERMANN.....5
 Marker, FREEMAN4
 Marker, GROSSMAN.....4
 Marker, HALPREN.....5
 Marker, McKISSOCK.....5
 MARYLAND, endoscopic grasper157
 MASING, elevator.....102
 MASING-NEIVERT, retractor.....87
 MAYO, scissors13
 MAYO-HABERISSER, wire twisting forceps.....97
 MAYO-HEGAR, needle holder92
 MAYO-STILLE, scissors14
 MC INDOE, bone cutting forceps99

MC INDOE, scissors.....29
 McINDOE, dressing forceps42
 McINDOE, tissue forceps42
 McIVOR, mouth gag144
 McKENTY, elevator102-103
 McKISSOCK, marker.....5
 MEAD, mallet.....100
 Metal, ruler.....2
 METZENBAUM, Endoscopic Scissors156
 METZENBAUM, scissors16-17
 METZENBAUM-FINO, scissors.....17
 MEYERDING, retractor74
 Micro ring, forceps48
 Micro suture tying, forceps47
 Micro, scissors.....33-35
 MICRO-HARTMANN, forceps59
 MICROVASCULAR, needle holder.....93
 MIDDLETON-JANSEN, septum forceps123
 MILLARD thimble hook.....84
 MILLER, retractor86
 MINI-LAMBOTTE, osteotome.....132
 MINI-LANGENBECK, dissector.....77
 MOD. BONN, suture forceps54
 MOD. TUEBINGEN, suture forceps ...54
 Mod. WIEN, nasal specula112
 MOELTGEN, goniometer.....2
 Monopolar, J-Hook electrode.....158
 Monopolar, Spatula electrode.....158
 Mouth gag, DAVIS-BOYLE.....142
 Mouth gag, DAVIS-MEYER144
 Mouth gag, DINGMANN.....143
 Mouth gag, KILNER-DOUGHTY143
 Mouth gag, McIVOR.....144
 Muscle forceps, BERKE55
 MYLES, nasal cutting forceps121

N

Nasal cutting scissors, CAPLAN122
 Nasal cutting scissors, GORNEY122
 Nasal cutting forceps, MYLES.....121
 Nasal cutting forceps, SCHMEDEN121
 Nasal cutting forceps, TAKAHASHI121
 Nasal cutting forceps, WEIL-BLAKESLEY120
 Nasal forceps, HEYMANN-KNIGHT..118
 Nasal forceps, KNIGHT118
 Nasal forceps, LUBET-BARBON.....117

Nasal forceps, WESTMACOTT	117
Nasal rasp, AUFRICHT	135
Nasal rasp, DINGMAN	138
Nasal rasp, FOMON	136-137
Nasal rasp, FOMON	137
Nasal rasp, GLABELLA	134
Nasal rasp, JOSEPH	134
Nasal rasp, JOSEPH (LEWIS)	135
Nasal rasp, MALTZ	134
Nasal rasp, MALTZ (COTTLE)	135
Nasal rasp, PARKES	134
Nasal rasp, PEET	134
Nasal rasp, WIENER	134
Nasal rasp, wire brush	138
Nasal saw, JOSEPH	138-139
Nasal specula, COTTLE	115-116
Nasal specula, HARTMANN	111
Nasal specula, HARTMANN-HALLE	110
Nasal specula, KILLIAN	113-114
Nasal specula, Mod. WIEN	112
Nasal specula, REDA	112
Nasal specula, TIECK-HALLE	112
Needle holder, BABY OLSEN-HEGAR	93
Needle holder, BARRAQUER	95
Needle holder, BAUMGARTNER	92
Needle holder, CASTROVIEJO	96
Needle holder, CRILE-WOOD	92
Needle holder, DeBAKEY	92
Needle holder, DERF	91
Needle holder, GILLIES	94
Needle holder, HALSEY	91
Needle holder, MAYO-HEGAR	92
Needle holder, MICROVASCULAR	93
Needle holder, OLSEN-HEGAR	93
Needle holder, RYDER	93
Needle holder, WEBSTER	91
NEIVERT-ANDERSON, osteotome	130
Nerve, hook	77
NEWS, hook	90
Nylon cap, mallet	100

O

O'BRIEN, scissors	28
OBWEGESER, elevator	149
OBWEGESER, osteotome	131
OBWEGESER, retractor	146-148
OCHSNER, dressing forceps	45
O'CONNOR, retractor	86

OEHLER, tissue forceps	37
OLSEN-HEGAR, needle holder	93
Osteotome, CINELLI	127
Osteotome, COTTLE	129
Osteotome, FOMON	127
Osteotome, MINI-LAMBOTTE	132
Osteotome, NEIVERT-ANDERSON	130
Osteotome, OBWEGESER	131
Osteotome, RUBIN	129
Osteotome, SHEEHAN	127
Osteotome, SILVER	130
Osteotome, TESSIER	151

P

PARKES, nasal rasp	134
PARTSCH, mallet	100
PECK-JOSEPH, scissors	31
PEET, nasal rasp	134
Pelvimeter, COLLIER	5
PENNINGTON, elevator	103
PIERCE, elevator	103
PITANGUY, facelift marker	3
Plastic surgery, endoscope	153
Plastic surgery, Endoscope Shaft	153-155
POTTS-SMITH, dressing forceps	36
POTTS-SMITH, tissue forceps	36
Probe, SINUS	103
PROVIDENCE-HOSPITAL, forceps	61

Q

QUISLING, mallet	100
------------------------	-----

R

RAGNELL, retractor	65
RAMUS, retractor	148
Raspatory, FOMON	101
Raspatory, JOSEPH	101
Raspatory, TESSIER	150
REDA, knife	125
REDA, nasal specula	112
REDA, retractor	72
Retractor with Endoscope Shaft, SCULPO	79
Retractor, ALM	75
Retractor, ANDERSON	84
Retractor, AUFRICHT	87
Retractor, BARSKY	71
Retractor, BIGGS	79
Retractor, BREAST	80

Retractor, CONVERSE	87
Retractor, CONVERSE	89
Retractor, CORONAL	84
Retractor, COTTLE	87-89
Retractor, COTTLE-NEIVERT	88
Retractor, CRILE	65
Retractor, DEAVER	67-68
Retractor, DESMARRES	73
Retractor, FARABEUF	65
Retractor, FERRIERA	78
Retractor, FINSEN	75
Retractor, FOMON	88
Retractor, FREEMAN	68, 84
Retractor, FREER	88
Retractor, GILLIES	89
Retractor, GORNEY	84
Retractor, GRAEFE	69
Retractor, GUTHRIE	69
Retractor, HOLZHEIMER	75
Retractor, HUMBY	71
Retractor, JANSEN	75
Retractor, JOSEPH	70
Retractor, KASDAN	73
Retractor, KILNER	88
Retractor, KLAPP	72
Retractor, KLEINERT-KUTZ	70
Retractor, KNAPP	86
Retractor, LAHEY	70
Retractor, LANGE	89
Retractor, MALINIAC	87
Retractor, MASING-NEIVERT	87
Retractor, MEYERDING	74
Retractor, MILLER	86
Retractor, OBWEGESER	146-148
Retractor, O'CONNOR	86
Retractor, RAGNELL	65
Retractor, RAMUS	148
Retractor, REDA	72
Retractor, RIBBON	66
Retractor, ROLLET	86
Retractor, ROUX	65
Retractor, SPINA-NASALIS	148
Retractor, STRANDELL-STILLE	74
Retractor, TEBBETS	78
Retractor, TYRELL	69
Retractor, VOLKMANN	73
Retractor, WEITLANER	76
Retractor, WIENER	86
Retractor, YANCOSKIE	83
Retractors for plastic surgery	78-81
REYNOLDS, scissors	19

REYNOLDS (Transauxillary),
Breast Dissectors 81-82
RIBBON, retractor66
ROCHESTER-OCHSNER, forceps63
ROCHESTER-PEAN, forceps63
ROLLET, retractor.....86
Rongeur, BEYER.....98
Rongeur, BÖHLER98
Rongeur, FRIEDMANN.....98
Rongeur, FRIEDMANN MINI98
ROUX, retractor.....65
RUBIN, osteotome.....129
RUBIN, septum forceps.....122
Ruler, metal2
RUSSEL-DAVIS , tongue depressor
.....145
RUSSIAN PATTERN, tissue forceps
.....42
RYDER, needle holder93

S

SANVENERO, scissors18
Scalpel, handles 8-12
SCHINK, dermatome.....6
SCHMEDEN, nasal cutting forceps
.....121
Scissors, BEUSE.....31
Scissors, BONN.....20
Scissors, CHADWICK26
Scissors, CONVERSE/WILMER/
WALTER.....22
Scissors, COTTLE.....22, 27
Scissors, COTTLE-MASING27
Scissors, FOMON.....27
Scissors, GOLDMAN-FOX29
Scissors, GORNEY30, 122
Scissors, GORNEY-FREEMAN30
Scissors, GRADLE23
Scissors, GRAEFE22
Scissors, GREENBERG-PAR.....32
Scissors, HEYMAN.....27
Scissors, IRIS.....20
Scissors, JOSEPH.....18
Scissors, KAYE.....33-32
Scissors, KELLY19
Scissors, KILNER19
Scissors, KNAPP21
Scissors, LA GRANGE26
Scissors, LEXER15
Scissors, LEXER-BABY15
Scissors, LITTAUER.....28

Scissors, LITTLER.....22
Scissors, MAYO.....13
Scissors, MAYO-STILLE14
Scissors, MC INDOE.....29
Scissors, METZENBAUM.....16-17
Scissors, METZENBAUM-FINO17
Scissors, micro33-35
Scissors, O'BRIEN28
Scissors, PECK-JOSEPH.....31
Scissors, REYNOLDS19
Scissors, SANVENERO18
Scissors, SPENCER.....28
Scissors, STEVENS24
Scissors, STRABISMUS.....24
Scissors, WAGNER.....25
Scissors, WILMER/CONVERSE22
SCULPO retractor with
Endoscope shaft.....79
SEMKEN, dressing forceps43
SEMKEN, tissue forceps43
septum chisels, CINELLI127
septum chisels, FOMON127
Septum forceps, BRUENINGS119
Septum forceps, CRAIG119
Septum forceps, LUC119
Septum forceps,
MIDDLETON-JANSEN123
Septum forceps, RUBIN122
Septum straightening forceps,ASCH.....
.....140
Septum straightening forceps,
WALSHAM140
SHEEHAN, Osteotom.....127
SILVER, dermatome.....7
SILVER, osteotome130
SILVERSTEIN, dissector82
SINGLEY, dressing forceps45
SINUS, probe103
Skin plate for dermatomes.....6
Spare blades for dermatomes6-7
Spatula electrode, monopolar.....158
Spatula, breast80
SPENCER, scissors28
SPINA-NASALIS, retractor148
Splinter, forceps.....46
STEVENS, scissors.....24
STILLE, dressing forceps36
STILLE, tissue forceps37
STILLE-BARRAYA, tissue forceps45
STRABISMUS, scissors24
STRANDELL-STILLE, retractor.....74

Suction tube, ADSON107
Suction tube, BARON.....107
Suction tube,
FRAZIER/FERGUSSON108
Suction tube, GUILLEN109
Suture forceps, CASTROVIEJO.....55
Suture forceps, MOD. BONN54
Suture forceps, MOD. TUEBINGEN...54

T

TAKAHASHI, nasal cutting
forceps.....121
TAYLOR, dressing forceps44
TAYLOR, tissue forceps44
TEBBETS, retractor.....78
TEBBETTS, dissector.....81
TESSIER, osteotome151
TESSIER, raspatory150
TIECK-HALLE, nasal specula112
Tissue forceps, ADSON.....38-39
Tissue forceps, ADSON-BROWN.....40
Tissue forceps,
BEASELEY BABCOCK39
Tissue forceps, BONNEY45
Tissue forceps, BROWN41
Tissue forceps, COLLIN-DUVAL42
Tissue forceps, CUSHING.....41
Tissue forceps, DURANTE.....45
Tissue forceps, DUVAL.....42
Tissue forceps, FERRIS-SMITH.....42
Tissue forceps, GERALD44
Tissue forceps, GILLIES.....43
Tissue forceps, GRAEFE41
Tissue forceps, LERCHE.....41
Tissue forceps, McINDOE42
Tissue forceps, OEHLER37
Tissue forceps, POTTS-SMITH.....36
Tissue forceps, RUSSIAN PATTERN
.....42
Tissue forceps, SEMKEN43
Tissue forceps, STILLE37
Tissue forceps, STILLE-BARRAYA.....45
Tissue forceps, TAYLOR44
Tissue forceps, USA.....37
Tissue forceps, WAUGH.....41
Tissue, forceps36-37
Tongue depressor, ANDREW141
Tongue depressor, JENNINGS.....141
Tongue depressor, RUSSEL-DAVIS
.....145
Tongue depressor, WIEDER.....141

TROELTSCH, ear forceps57
 TYRELL, retractor.....69

U

USA, dressing forceps.....36
 USA, tissue forceps.....37

V

VOLKMANN, retractor73

W

WAGNER, scissors25
 WALSHAM, septum straightening
 forceps.....140
 WALTER/CONVERSE/WILMER,
 scissors.....22
 WATSON, dermatome7
 WAUGH, tissue forceps.....41
 WEBSTER, needle holder.....91
 WEIL-BLAKESLEY, Nasal Cutting
 forceps.....120
 WEITLANER, retractor76
 WEST, chisel132
 WEST, gouge.....132
 WESTMACOTT, nasal forceps117
 WIEDER, tongue depressor141
 WIENER, nasal rasp.....134
 WIENER, retractor.....86
 WILDE (TROELTSCH), ear forceps ...57
 WILLIGER, elevator.....101
 WILMER/CONVERSE/WALTER,
 scissors.....22
 Wire brush, nasal rasp.....138
 Wire twisting forceps, BERRY97
 Wire twisting forceps,
 MAYO-HABERISSER.....97

Y

YANCOSKIE, retractor83

A

Abre-boca DAVIS-BOYLE	142
Abre-boca DAVIS-MEYER	144
Abre-boca DINGMANN	143
Abre-boca JENNINGS.....	141
Abre-boca KILNER-DOUGHTY	143
Abre-boca McIVOR	144
ACKERMANN marcador para aréola	5
ADSON gancho para duramadre	85
ADSON micro pinza de diseccion.....	38-39
ADSON pinza de diseccion	38-39
ADSON pinza hemostatica.....	64
ADSON tubo de aspiracion	107
ADSON-BROWN pinza de diseccion.....	40
ADSON-DeBAKEY pinza de diseccion.....	38
AGRIS-DINGMAN separador mamario.....	81
ALM separador	75
ANDERSON separador	84
ANDREW baja-lengua.....	141
ASCH pinza para enderezar el tabique nasal	140
AUFRIEHT escofina nasal	135
AUFRIEHT separador nasal.....	87

B

BABY OLSEN-HEGAR porta aguja.....	93
Baja-lengua ANDREW.....	141
Baja-lengua McIVOR.....	144
Baja-lengua RUSSEL-DAVIS	145
Baja-lengua WIEDER.....	141
BALLENGER cuchillo para el tabique nasal	126
BALLENGER elevador para tabique.....	104
BARON tubo de aspiracion	107
BARRAQUER micro porta aguja.....	95
BARRAQUER pinza depilatoria.....	55
BARSKY separador.....	71
BAUMGARTNER porta aguja.....	92
BEASELEY BABCOCK pinza de diseccion	39
BERKE pinza muscular	55
BERRY pinza para torcer hilos.....	97
BEUSE Face Lift tijera.....	31
BEYER pinza gubia	98
BIGGS separador	79
BISHOP-HARMAN pinza para iris.....	53

BLAIR instrumento para labios y fisura palatina.....	106
BÖHLER pinza gubia	98-99
BOIES elevador.....	102
BONN Mod. pinza para sutura	54
BONN tijera fina.....	20
BONNEY pinza de diseccion	45
BREAST separador	81
BROWN pinza de diseccion	41
BRUENINGS pinza para el tabique nasal	119

C

Camisa para cirugía plástica	80, 153-155
Cánulas de liposucción.....	159 -163
CAPLAN tijera nasale.....	122
CASTROVIEJO compas.....	5
CASTROVIEJO micro porta aguja	96
CASTROVIEJO pinza para sutura	55
Cepillo de alambre	138
CHADWICK tijera fina	26
Cinzel CINELLI.....	127
Cinzel COTTLE	129
Cinzel nasal FOMON.....	127
Cinzel nasal FREER.....	128
Cinzel nasal SHEEHAN.....	127
Cinzel SILVER.....	130
COLLER-CRILE pinza hemostatica ...	61
COLLIER pelvimetro.....	5
COLLIN-DUVAL pinza de diseccion.....	42
Compas CASTROVIEJO.....	5
CONVERSE cuchillo nasal	125
CONVERSE separador	89
CONVERSE separador nasal.....	89
CONVERSE/WILMER/WALTER tijera fina	22
CORONAL separador.....	84
COTTLE cinzel	129
COTTLE cuchillo nasal	125
COTTLE elevador para tabique.....	104
COTTLE escofina nasal	135
COTTLE especulo nasal	115-116
COTTLE JOSEPH elevador	103
COTTLE legra	104
COTTLE macha cadera.....	133
COTTLE martillo.....	100
COTTLE osteotomo.....	129
COTTLE pinza para columela	57
COTTLE pinza para fijacion	57

COTTLE separador	89
COTTLE separador nasal.....	87-88
COTTLE tijera fina.....	22
COTTLE tijera nasal	27
COTTLE-KAZANJIAN pinza gubia.....	99
COTTLE-MASING tijera nasal	27
COTTLE-NEIVERT separador nasal.....	88
CRAIG pinza para el tabique nasal	119
CRILE gancho para nervios	85
CRILE pinza hemostatica	62
CRILE separador.....	65
CRILE-RANKIN pinza hemostatica.....	62
CRILE-WOOD porta aguja	92
CRONIN instrumento para labios y fisura palatina.....	106
Cuchillo nasal CONVERSE.....	125
Cuchillo nasal COTTLE.....	125
Cuchillo nasal FREER	124
Cuchillo nasal JOSEPH.....	124-125
Cuchillo nasal REDA	125
Cuchillo para el tabique nasal BALLENGER.....	126
CUSHING gancho para nervios	85
CUSHING pinza de diseccion	41
CUSHING-TAYLOR pinza de diseccion	44

D

D'ASSUMPACO instrumento para marcar	3
DAVIS-BOYLE abre-boca.....	142
DAVIS-MEYER abre-boca.....	144
DEAVER separador.....	67-68
DeBAKEY pinza atraumatica.....	51
DeBAKEY porta aguja	92
DERF porta aguja.....	91
Dermatomo HUMBY	7
Dermatomo SCHINK	6
Dermatomo SILVER	7
Dermatomo WATSON	7
DESMARRES pinza para chalazion....	55
DESMARRES separador.....	73
DINGMAN elevador.....	150
DINGMAN escofina nasal	138
DINGMAN legra.....	150
DINGMANN abre-boca.....	143
Disector GORNEY.....	102
Disector LANGENBECK.....	77
Disector LANGENBECK-COTTLE	77

Disector MINI-LANGENBECK.....77
 DURANTE pinza de diseccion45
 DUVAL pinza de diseccion42

E

Elevador BOIES102
 Elevador COTTLE JOSEPH.....103
 Elevador DINGMAN150
 Elevador FREER102
 Elevador HOWARTH.....103
 Elevador JOSEPH..... 102-103
 Elevador KILLIAN..... 103-104
 Elevador MASING102
 Elevador McKENTY..... 102-103
 Elevador para tabique
 BALLENGER.....104
 Elevador para tabique COTTLE104
 Elevador para tabique
 HAJEK-BALLENGER.....104
 Elevador PENNINGTON103
 Elevador PIERCE.....103
 Elevador SINUS103
 Escofina nasal AUFRICHT135
 Escofina nasal COTTLE135
 Escofina nasal DINGMAN138
 Escofina nasal FOMON..... 136-137
 Escofina nasal GLABELLA.....134
 Escofina nasal JOSEPH..... 134-135
 Escofina nasal LEWIS.....135
 Escofina nasal MALTZ..... 134-135
 Escofina nasal PARKES134
 Escofina nasal PEET.....134
 Escofina nasal WIENER.....134
 Espatula80
 Espatula abdominal e intestinal
 RIBBON.....66
 Especulo nasal COTTLE..... 115-116
 Especulo nasal HARTMANN 111
 Especulo nasal
 HARTMANN-HALLE..... 110
 Especulo nasal KILLIAN..... 113-114
 Especulo nasal Mod. WIEN..... 112
 Especulo nasal REDA 112
 Especulo nasal TIECK-HALLE..... 112

F

Face Lift tijera BEUSE.....31
 Face Lift tijera GORNEY30
 Face Lift tijera GORNEY-FREEMAN...30
 Face Lift tijera KAYE.....31
 Face Lift tijera PECK-JOSEPH.....31

FARABEU separador65
 FERGUSSON/FRAZIER tubo de
 aspiracion108
 FERRIERA separador78
 FERRIS-SMITH pinza de
 diseccion.....42
 FINSEN separador75
 FOMON cinceles nasal.....127
 FOMON escofina nasal 136-137
 FOMON legra101
 FOMON separador nasal88
 FOMON tijera nasal27
 FRAZIER separador.....70
 FRAZIER/FERGUSSON tubo de
 aspiracion108
 FREEMAN marcador para aréola.....4
 FREEMAN separador.....68, 84
 FREER Cincel nasal.....128
 FREER cuchillo nasal124
 FREER elevador.....102
 FREER gubia.....132
 FREER separador nasal88
 FRIEDMANN MICRO pinza gubia.....98
 FRIEDMANN MINI pinza gubia98
 FRIEDMANN pinza gubia.....98

G

Gancho MILLARD84
 Gancho para duramadre ADSON.....85
 Gancho para nervios77, 85
 Gancho para nervios CRILE.....85
 Gancho para nervios CUSHING.....85
 Gancho para traqueotomia
 JACKSON.....90
 Gancho para traqueotomia NEWS.....90
 GERALD pinza de diseccion 43-44
 GERZOG martillo100
 GILLIES pinza de diseccion43
 GILLIES porta aguja.....94
 GILLIES separador.....89
 GLABELLA escofina nasal134
 GOLDMAN-FOX tijera para encias29
 Goniometro MOELTGEN.....2
 Goniometro para dedos.....2
 GORNEY disector102
 GORNEY Face Lift tijera30
 GORNEY separador.....84
 GORNEY tijera para nasale122
 GORNEY-FREEMAN
 Face Lift tijera30
 GRADLE tijera fina23

GRAEFE pinza de diseccion41
 GRAEFE pinza para iris52
 GRAEFE separador69
 GRAEFE tijera fina22
 GREEN pinza para fijacion.....56
 GREENBERG-PAR tijera para
 blefaroplastia32
 GROSSMAN marcador para aréola4
 Gubia FREER.....132
 Gubia HAJEK132
 Gubia KILLIAN130
 Gubia KILLIAN-CLAUS132
 Gubia WEST.....132
 GUILLEN tubo de aspiracion109
 GUTHRIE separador69

H

HAJEK gubia132
 HAJEK-BALLENGER elevador
 para tabique.....104
 HALPREN marcador para aréola5
 HALSEY porta aguja91
 HALSTEAD-MOSQUITO micro
 pinza hemostatica.....60
 HALSTEAD-MOSQUITO pinza
 hemostatica60
 HARTMANN especulo nasal 111
 HARTMANN pinza hemostatica59
 HARTMANN pinza para polipos117
 HARTMANN-HALLE especulo
 nasal110
 HEYMAN tijera nasal27
 HEYMANN-KNIGHT pinza
 para polipos118
 Hoja de repuesto para dermatomo ... 6-7
 HOLZHEIMER separador.....75
 HOWARTH elevador103
 HUMBY dermatomo7
 HUMBY separador71

I

Instrumento para labios y fisura
 palatina BLAIR.....106
 Instrumento para labios y
 fisura palatina CRIONIN.....106
 Instrumento para marcar
 D'ASSUMPACO3
 Instrumento para marcar
 LOCKWOOD3
 Instrumentos para endoscopia
 152-158

Instrumentos para labios y fisura palatina 105-106
IRIS tijera fina 20

J

JACKSON gancho para traqueotomia 90
JAEGER placa para parado 58
JANSEN separador 75
JANSEN-GRUENWALD pinza auricular 57
JENNINGS abre-boca 141
JOSEPH cuchillo nasal 124-125
JOSEPH elevador 102-103
JOSEPH escofina nasal 134-135
JOSEPH legra 101
JOSEPH separador 70
JOSEPH sierra nasal 138-139
JOSEPH tijera de diseccion 18
JOST macha cadera 133

K

KASDAN separador 73
KAYE Face Lift tijera 31
KAYE tijera para blefaroplastia 32
KELLY pinza hemostatica 61
KELLY tijera de diseccion 19
KELLY-RANKIN pinza hemostatica 61
KILLIAN elevador 103-104
KILLIAN especulo nasal 113-114
KILLIAN gubia 130
KILLIAN-CLAUS gubia 132
KILLNER separador nasal 88
KILNER RAGNELL tijera de diseccion 19
KILNER-DOUGHTY abre-boca 143
KLAPP separador 72
KLEINERT-LUTZ separador 70
KNAPP separador 86
KNAPP tijera fina 21
KNIGHT pinza para el tabique nasal 118

L

LA GRANGE tijera fina 26
LAHEY separador 70
LAMBOTTE-MINI osteotomo 132
LANGE separador 89
LANGENBECK disector 77
LANGENBECK legra 101

LANGENBECK-COTTLE disector 77
Legra COTTLE 104
Legra DINGMAN 150
Legra FOMON 101
Legra JOSEPH 101
Legra LANGENBECK 101
Legra OBWEGESER 149
Legra WILLIGER 101
LERCHE pinza de diseccion 41
LERICHE pinza hemostatica 63
LEWIS escofina nasal 135
LEXER tijera de diseccion 15
LEXER-BABY tijera de diseccion 15
LITTAUER tijera para hilos 28
LITTLER tijera fina 22
LOCKWOOD instrumento para marcar 3
LOCKWOOD, Separador mamaros 82
LUBET-BARBON pinza para taponamiento 117
LUC pinza para el tabique nasal 119
LUCAE pinza auricular 57

M

MacCOLLUM-DINGMAN separador mamario 81
Macha cadera COTTLE 133
Macha cadera JOST 133
MALINIAC separador nasal 87
MALTZ escofina nasal 134-135
Mango de bisturie 8-12
Marcador para aréola ACKERMANN 5
Marcador para aréola FREEMAN 4
Marcador para aréola GROSSMAN 4
Marcador para aréola HALPREN 5
Marcador para aréola McKISSOCK 5
Marcador para facelift PITANGUY 3
Martillo COTTLE 100
Martillo GERZOG 100
Martillo MEAD 100
Martillo PARTSCH 100
Martillo QUISLING 100
Martillos 100
MARTINEZ-KILNER separador 89
MASING elevador 102
MASING-NEIVERT separador nasal 87
MAYO tijera de diseccion 13
MAYO-HABERISSER pinza para torcer hilos 97

MAYO-HEGAR porta aguja 92
MAYO-STILLE tijera de diseccion 14
MC INDOE pinza gubia 99
MC INDOE tijera para cartilago 29
McINDOE pinza de diseccion 42
McIVOR abre-boca 144
McIVOR baja-lengua 144
McKENTY elevador 102-103
McKISSOCK marcador para aréola 5
MEAD martillo 100
METZENBAUM tijera de diseccion 16-17
METZENBAUM-FINO tijera de diseccion 17
MEYERDING separador 74
MICRO FRIEDMANN pinza gubia 98
Micro pinzas 47-49
Micro porta aguja BARRAQUER 95
Micro porta aguja CASTROVIEJO 96
Micro tijeras 33-35
MICROVASCULAR porta aguja 93
MIDDLETON-JANSEN pinza para el tabique nasal 123
MILLARD gancho 84
MILLER separador 86
MINI-LAMBOTTE osteotomo 132
MINI-LANGENBECK disector 77
Mod. BONN pinza para sutura 54
Mod. RUSO pinza de diseccion 42
Mod. TUEBINGEN pinza para sutura 54
Mod. WIEN especulo nasal 112
MOELTGEN goniometro 2
MYLES pinza cortante nasal 121

N

NEIVERT-ANDERSON osteotomo 130
NEWS gancho para traqueotomia 90

O

O'BRIEN tijera para hilos 28
O'CONNOR separador 86
OBWEGESER legra 149
OBWEGESER osteotomo 131
OBWEGESER separador para cirugiade boca-mandibula-fiscal 146-148
OCHSNER pinza de diseccion 45
OEHLER pinza de diseccion 37
OLSEN-HEGAR BABY porta aguja 93

OLSEN-HEGAR porta aguja93
 Osteotomo CINELLI127
 Osteotomo COTTLE.....129
 Osteotomo MINI-LAMBOTTE.....132
 Osteotomo NEIVERT-ANDERSON...130
 Osteotomo OBWEGESER131
 Osteotomo RUBIN.....129
 Osteotomo SHEEHAN.....127
 Osteotomo TESSIER.....151
 Osteotomo WEST.....132

P

PARKES escofina nasal134
 PARTSCH martillo100
 PECK-JOSEPH Face Lift tijera.....31
 PEET escofina nasal134
 Pelvimetro COLLIER5
 PENNINGTON elevador.....103
 PIERCE elevador103
 Pinza atraumatica DeBAKEY51
 Pinza auricular
 JANSEN-GRUENWALD.....57
 Pinza auricular LUCAE.....57
 Pinza auricular TROELTSCH57
 Pinza auricular WILDE
 (TROELTSCH).....57
 Pinza cortante nasal MYLES.....121
 Pinza cortante nasal SCHMEDEN121
 Pinza cortante nasal TAKAHASHI.....121
 Pinza cortante nasal
 WEIL-BLAKESLEY.....120
 Pinza de diseccion ADSON..... 38-39
 Pinza de diseccion ADSON micro
 38-39
 Pinza de diseccion
 ADSON-BROWN.....40
 Pinza de diseccion
 ADSON-DeBAKEY38
 Pinza de diseccion BEASELEY
 BABCOCK.....39
 Pinza de diseccion BONNEY45
 Pinza de diseccion BROWN.....41
 Pinza de diseccion COLLIN-DUVAL...42
 Pinza de diseccion CUSHING41
 Pinza de diseccion
 CUSHING-TAYLOR.....44
 Pinza de diseccion DURANTE45
 Pinza de diseccion DUVAL.....42
 Pinza de diseccion
 FERRIS-SMITH.....42
 Pinza de diseccion GERALD..... 43-44

Pinza de diseccion GILLIES43
 Pinza de diseccion GRAEFE.....41
 Pinza de diseccion LERCHE.....41
 Pinza de diseccion McINDOE42
 Pinza de diseccion Mod. RUSO42
 Pinza de diseccion OCHSNER.....45
 Pinza de diseccion OEHLER.....37
 Pinza de diseccion POTTS-SMITH36
 Pinza de diseccion SEMKEN43
 Pinza de diseccion SINGLEY45
 Pinza de diseccion STILLE..... 36-37
 Pinza de diseccion
 STILLE-BARRAYA.....45
 Pinza de diseccion TAYLOR44
 Pinza de diseccion
 TAYLOR-CUSHING44
 Pinza de diseccion USA 36-37
 Pinza de diseccion WAUGH.....41
 Pinza depilatoria BARRAQUER55
 Pinza gubia BEYER.....98
 Pinza gubia BÖHLER..... 98-99
 Pinza gubia COTTLE-KAZANJIAN.....99
 Pinza gubia FRIEDMANN98
 Pinza gubia FRIEDMANN MINI.....98
 Pinza gubia MC INDOE.....99
 Pinza gubia MICRO FRIEDMANN98
 Pinza hemostatica ADSON.....64
 Pinza hemostatica COLLER-CRILE61
 Pinza hemostatica CRILE.....62
 Pinza hemostatica CRILE-RANKIN.....62
 Pinza hemostatica
 HALSTEAD-MOSQUITO60
 Pinza hemostatica
 HALSTEAD-MOSQUITO micro60
 Pinza hemostatica HARTMANN59
 Pinza hemostatica KELLY61
 Pinza hemostatica KELLY-RANKIN.....61
 Pinza hemostatica LERICHE.....63
 Pinza hemostatica
 PROVIDENCE-HOSPITAL61
 Pinza hemostatica
 ROCHESTER-OCHSNER.....63
 Pinza hemostatica
 ROCHESTER-PEAN63
 Pinza muscular BERKE.....55
 Pinza para chalazion DESMARRS ...55
 Pinza para columela COTTLE.....57
 Pinza para el tabique nasal
 BRUENINGS 119
 Pinza para el tabique nasal CRAIG.....
 119

Pinza para el tabique nasal KNIGHT.....
 118
 Pinza para el tabique nasal LUC
 119
 Pinza para el tabique nasal
 MIDDLETON-JANSEN123
 Pinza para el tabique nasal RUBIN.....
 122
 Pinza para enderezar el tabique
 nasal ASCH140
 Pinza para enderezar el tabique
 nasal WALSHAM.....140
 Pinza para fijacion COTTLE57
 Pinza para fijacion GREEN56
 Pinza para iris BISHOP-HARMAN53
 Pinza para iris GRAEFE52
 Pinza para polipos HARTMANN..... 117
 Pinza para polipos
 HEYMANN-KNIGHT 118
 Pinza para sutura CASTROVIEJO55
 Pinza para sutura Mod. BONN54
 Pinza para sutura
 Mod. TUEBINGEN.....54
 Pinza para taponamiento
 LUBET-BARBON 117
 Pinza para taponamiento
 WESTMACOTT 117
 Pinza para torcer hilos BERRY97
 Pinza para torcer hilos
 MAYO-HABERISSER.....97
 Pinzas atraumaticas con TC.....50
 Pinzas de diseccion sin y con
 dientes 36-45
 Pinzas para espinas46
 PITANGUY marcador para facelift.....3
 Placa para extender la piel6
 Placa para parado JAEGER.....58
 Porta aguja BABY OLSEN-HEGAR93
 Porta aguja BAUMGARTNER92
 Porta aguja CRILE-WOOD.....92
 Porta aguja DeBAKEY92
 Porta aguja DERF91
 Porta aguja GILLIES.....94
 Porta aguja HALSEY91
 Porta aguja MAYO-HEGAR.....92
 Porta aguja MICROVASCULAR93
 Porta aguja OLSEN-HEGAR93
 Porta aguja RYDER.....93
 Porta aguja WEBSTER91
 POTTS-SMITH pinza de diseccion.....36
 PROVIDENCE-HOSPITAL pinza
 hemostatica61

Q

QUISLING martillo.....100

R

RAGNELL separador.....65
 RAMUS separador para cirugía de boca-mandibula-fiscal.....148
 REDA cuchillo nasal.....125
 REDA especulo nasal.....112
 REDA separador.....72
 Regla.....2
 REYNOLDS JAMESON tijera de diseccion.....19
 REYNOLDS (Transauxillary) Separadores mamarios.....81-82
 RIBBON espatula abdominal e intestinal.....66
 ROCHESTER-OCHSNER pinza hemostatica.....63
 ROCHESTER-PEAN pinza hemostatica.....63
 ROLLET separador.....86
 ROUX mini separador.....65
 RUBIN osteotomo.....129
 RUBIN pinza para el tabique nasal.....122
 RUSO Mod. pinza de diseccion.....42
 RUSSEL-DAVIS baja-lengua.....145
 RYDER porta aguja.....93

S

SANVENERO tijera de diseccion.....18
 SCHINK dermatomo.....6
 SCHMEDEN pinza cortante nasal.....121
 SCULPO separador con camisa para cirugía plástica.....79
 SEMKEN pinza de diseccion.....43
 Separador ALM.....75
 Separador ANDERSON.....84
 Separador BARSKY.....71
 Separador BIGGS.....79
 Separador BREAST.....81
 Separador con camisa para cirugía plástica SCULPO.....79
 Separador CONVERSE.....89
 Separador CORONAL.....84
 Separador COTTLE.....89
 Separador CRILE.....65
 Separador de mobilizacion TESSIER.....150
 Separador DEEVER.....67-68
 Separador DESMARRES.....73

Separador FARABEUF.....65
 Separador FERRIERA.....78
 Separador FINSEN.....75
 Separador FRAZIER.....70
 Separador FREEMAN.....68, 84
 Separador GILLIES.....89
 Separador GORNEY.....84
 Separador GRAEFE.....69
 Separador GUTHRIE.....69
 Separador HOLZHEIMER.....75
 Separador HUMBY.....71
 Separador JANSEN.....75
 Separador JOSEPH.....70
 Separador KASDAN.....73
 Separador KLAPP.....72
 Separador KLEINERT-LUTZ.....70
 Separador KNAPP.....86
 Separador LAHEY.....70
 Separador LANGE.....89
 Separador mamario AGRIS-DINGMAN.....81
 Separador mamario MacCOLLUM-DINGMAN.....81
 Separador mamarios LOCKWOOD.....82
 Separador mamario REYNOLDS (Transauxillary).....81
 Separador mamario SILVERSTEIN.....82
 Separador mamario TEBBETTS.....81
 Separador MARTINEZ-KILNER.....89
 Separador MEYERDING.....74
 Separador MILLER.....86
 Separador nasal AUFRICT.....87
 Separador nasal CONVERSE.....87
 Separador nasal COTTLE.....87-89
 Separador nasal COTTLE-NEIVERT.....88
 Separador nasal FOMON.....88
 Separador nasal FREER.....88
 Separador nasal KILLNER.....88
 Separador nasal MALINIAC.....87
 Separador nasal MASING-NEIVERT.....87
 Separador O'CONNOR.....86
 Separador para cirugía de boca-mandibula-fiscal OBWEGESER.....146-148
 Separador para cirugía de boca-mandibula-fiscal RAMUS.....148
 Separador para cirugía de boca-mandibula-fiscal SPINA-NASALIS.....148

Separador RAGNELL.....65
 Separador REDA.....72
 Separador ROLLET.....86
 Separador ROUX mini.....65
 Separador STRANDELL-STILLE.....74
 Separador TEBBETTS.....78
 Separador TYRELL.....69
 Separador VOLKMANN.....73
 Separador WEITLANER.....76
 Separador WIENER.....86
 Separador YANCOSKIE.....83
 Separadores para cirugía plástica.....78-81
 Sierra nasal JOSEPH.....138-139
 SHEEHAN cincel.....127
 SILVER cincel.....130
 SILVER dermatomo.....7
 SILVERSTEIN separador mamario.....82
 SINGLEY pinza de diseccion.....45
 SINUS elevador.....103
 SPENCER tijera para hilos.....28
 SPINA-NASALIS separador para cirugía de boca-mandibula-fiscal.....148
 STEVENS tijera fina.....24
 STILLE pinza de diseccion.....36-37
 STILLE-BARRAYA pinza de diseccion.....45
 STRABISMUS tijera fina.....24
 STRANDELL-STILLE separador.....74

T

TAKAHASHI pinza cortante nasal.....121
 TAYLOR pinza de diseccion.....44
 TAYLOR-CUSHING pinza de diseccion.....44
 TEBBETTS separador.....78
 TEBBETTS separador mamario.....81
 TESSIER osteotomo.....151
 TESSIER separador de mobilizacion.....150
 TIECK-HALLE especulo nasal.....112
 Tijera de diseccion JOSEPH.....18
 Tijera de diseccion KELLY.....19
 Tijera de diseccion KILNER RAGNELL.....19
 Tijera de diseccion LEXER.....15
 Tijera de diseccion LEXER-BABY.....15
 Tijera de diseccion MAYO.....13
 Tijera de diseccion MAYO-STILLE.....14
 Tijera de diseccion METZENBAUM.....16-17

Tijera de diseccion	
METZENBAUM-FINO.....	17
Tijera de diseccion REYNOLDS	
JAMESON.....	19
Tijera de diseccion SANVENERO.....	18
Tijera fina BONN.....	20
Tijera fina CHADWICK.....	26
Tijera fina CONVERSE/WILMER/ WALTER.....	22
Tijera fina COTTLE.....	22
Tijera fina GRADLE.....	23
Tijera fina GRAEFE.....	22
Tijera fina IRIS.....	20
Tijera fina KNAPP.....	21
Tijera fina LA GRANGE.....	26
Tijera fina LITTLER.....	22
Tijera fina para oftalmologia.....	23
Tijera fina STEVENS.....	24
Tijera fina STRABISMUS.....	24
Tijera fina WAGNER.....	25
Tijera fina WILMER/CONVERSE.....	22
Tijera nasal COTTLE.....	27
Tijera nasal COTTLE-MASING.....	27
Tijera nasal FOMON.....	27
Tijera nasal HEYMAN.....	27
Tijera para blefaroplastia	
GREENBERG-PAR.....	32
Tijera para blefaroplastia KAYE.....	32
Tijera para cartilago MC INDOE.....	29
Tijera para encias GOLDMAN-FOX.....	29
Tijera para hilos LITTAUER.....	28
Tijera para hilos O'BRIEN.....	28
Tijera para hilos SPENCER.....	28
Tijera para nasales CAPLAN.....	122
Tijera para nasales GORNEY.....	122
TROELTSCH pinza auricular.....	57
Tubo de aspiracion ADSON.....	107
Tubo de aspiracion BARON.....	107
Tubo de aspiracion	
FRAZIER/FERGUSSON.....	108
Tubo de aspiracion GUILLEN.....	109
TUEBINGEN Mod. pinza para sutura.....	54
TYRELL separador.....	69

U

USA pinza de diseccion.....	36-37
-----------------------------	-------

V

VOLKMANN separador.....	73
-------------------------	----

W

WAGNER tijera fina.....	25
WALSHAM pinza para enderezar el tabique nasal.....	140
WALTER/CONVERSE/WILMER	
tijera fina.....	22
WATSON dermatomo.....	7
WAUGH pinza de diseccion.....	41
WEBSTER porta aguja.....	91
WEIL-BLAKESLEY pinza cortante nasal.....	120
WEITLANER separador.....	76
WEST gubia.....	132
WEST osteotomo.....	132
WESTMACOTT pinza para taponamiento.....	117
WIEDER baja-lengua.....	141
WIEN Mod. espejulo nasal.....	112
WIENER escofina nasal.....	134
WIENER separador.....	86
WILDE (TROELTSCH) pinza auricular.....	57
WILLIGER legra.....	101
WILMER/CONVERSE/WALTER	
tijera fina.....	22

Y

YANCOSKIE separador.....	83
--------------------------	----

A

Abbassalingua Andrew	141
Abbassalingua Davis-Boyle	142
Abbassalingua Dingmann	143
Abbassalingua Kilner-Doughty	143
Abbassalingua Russel-Davis	145
Abbassalingua Wieder	141
ACKERMANN strumento per marcare	5
ADSON cannula di aspirazione	107
ADSON pinza emostatica	64
ADSON uncini per dura-madre	85
AGRIS-DINGMAN separatori mammari	81
ALM divaricatori	75
ANDERSON uncini per pelle	84
ANDREW abbassalingua	141
Apribocca completo Davis-Boyle	142
Apribocca Dingmann	143
Apribocca Jennings	141
Apribocca Kilner-Doughty	143
ASCH pinza per raddrizzare il setto nasale	140
AUFRICHT raspa nasale	135
AUFRICHT retrattori nasali	87

B

Baby OLSEN HEGAR portaghi	93
BABY-WEBSTER portaghi	91
BALLENGER coltello per setto	126
BALLENGER elevatore per setto	104
BARON Cannula di aspirazione	107
BARRAQUER micro portaghi	95
BARRAQUER pinza depilatoria	55
BARSKY uncinetto per pelle	71
BAUMGARTNER portaghi	92
BERKE pinze muscolari	55
BERRY Pinza torcifili	97
BEUSE face lift forbici	31
BEYER pinza sgorbia	98
BIGGS divaricatore con luce fredda	79
BISHOP-HARMAN pinze per iride	53
Bisturi per cartilagine Joseph	124
Bisturi per rinoplastica Converse	125
Bisturi per rinoplastica Cottle	125
Bisturi per rinoplastica Joseph	124
BLAIR elevatore per fessure del palato	106
BOEHLER cesoie per ossa	99
BOEHLER pinza sgorbia	98
BOIES sgorbia periostotomo	102

BONN forbice delicata	20
BONNEY pinza anatomica	45
BONNEY pinze chirurgiche	45
BREAST divaricatore	80
BROWN Pinze chirurgiche	41
BRUENINGS pinza per il setto nasale	119

C

Camicia per chirurgia plastica	80,
.....	153-155
Cannula di aspirazione	107
Cannula di aspirazione Baron	107
Cannula di aspirazione Guilen	109
Cannule di aspirazione Frazier/Fergusson	108
Cannule per liposuzione	159 -163
CAPLAN forbici nasali	122
CASTROVIEJO compasso	5
CASTROVIEJO micro portaghi	96
CASTROVIEJO pinze per sutura	55
CHADWICK forbici gengivali	26
CINELLI scalpelli nasale	127
COLLER-CRILE pinze emostatiche	61
COLLIER compasso	5
COLLIN DUVAL pinza fenestrata	42
Coltello falcato REDA	125
Coltello per il setto nasale Freer	124
Coltello per mucosa Freer	124
Coltello per setto BALLENGER	126
Compasso Castroviejo	5
Compasso Collier	5
CONVERSE bisturi per rinoplastica	125
CONVERSE divaricatore	89
CONVERSE retrattori nasali	87
CONVERSE/WILMER/WALTER forbici delicate	22
CORONAL divaricatore	84
COTTLE bisturi per setto nasale	125
COTTLE divaricatori	89
COTTLE elevatore per setto	103-104
Cottle forbici delicate	22
COTTLE forbici nasali	27
COTTLE KAZANJIAN cesoia per ossa	99
COTTLE martello metallico	100
COTTLE osteotomo	129
COTTLE pinza per columella	57
COTTLE retrattore nasale	87-88
COTTLE scalpello per plastica nasale	129

Cottle specoli nasali	115-116
COTTLE Tritacartilagine	133
COTTLE-JOSEPH elevatore per setto	103
COTTLE-MASING forbici nasali	27
COTTLE-NEIVERT retrattore nasale	88
CRAIG pinza per il setto nasale	119
CRILE divaricatore doppio	65
CRILE pinze emostatiche	62
CRILE RANKIN pinze emostatiche	62
CRILE uncini per nervi	85
CRILE WOOD portaghi	92
CRONIN coltello	105
CUSHING pinza anatomica	41
CUSHING pinza chirurgica 1x2	41
CUSHING uncini per nervi	85
CUSHING-TAYLOR pinza a baionetta	44

D

D'ASSUMPCAO strumento per marcare	3
DAVIS BOYLE abbassalingua	142
DAVIS BOYLE apribocca completo	142
DAVIS BOYLE Telaio solo	142
DAVIS MEYER Telaio solo	144
DE BAKEY portaghi	92
DEAVER divaricatori addominali	67-68
DEBAKEY micro pinza atraumatica	49
DEBAKEY pinze atraumatiche	51
DEBAKEY pinze atraumatiche TC	50
DERF portaghi	91
Dermatomo Humby	7
Dermatomo Schink	6
Dermatomo Silver	7
Dermatomo Watson	7
DESMARRES divaricatori	73
DESMARRES pinze per calazio	55
DINGMAN divaricatore	150
DINGMAN periostotomo doppio	150
DINGMAN raspa nasale	138
DINGMANN abbassalingua	143
DINGMANN apribocca	143
Dischi di ricambio per martello	100
Dissettore Gorney	102
Dissettori Williger	101
Divaricat. dopp. coppia Farabeuf	65
Divaricatore	150
Divaricatore Breast	80
Divaricatore con luce fredda Biggs	79

Divaricatore Converse.....	89
Divaricatore Coronal.....	84
Divaricatore Dingman.....	150
Divaricatore doppio Crile.....	65
Divaricatore doppio Ragnel.....	65
Divaricatore doppio Roux.....	65
Divaricatore Gorney.....	84
Divaricatore Kasdan.....	73
Divaricatore Knapp.....	86
Divaricatore Lange.....	89
Divaricatore Martinez-Kilner.....	89
Divaricatore Miller.....	86
Divaricatore Obwegeser.....	146-148
Divaricatore O'Connor.....	86
Divaricatore per chirurgia plastica.....	78-81
Divaricatore Ramus.....	148
Divaricatore Rollet.....	86
Divaricatore Spina-Nasalis.....	148
Divaricatore Tessier.....	150
Divaricatori.....	72
Divaricatori addominali DEEVER... 67-68	
Divaricatori Alm.....	75
Divaricatori con camicia per chirurgia plastica Sculpo.....	79
Divaricatori Cottle.....	89
Divaricatori Desmarres.....	73
Divaricatori Ferriera.....	78
Divaricatori Finsen.....	75
Divaricatori Freeman.....	68, 84
Divaricatori Gillies.....	89
Divaricatori Holzheimer.....	75
Divaricatori Jansen.....	75
Divaricatori Klapp.....	72
Divaricatori Lahey.....	70
Divaricatori Meyerding.....	74
Divaricatori Strandel-Stille.....	74
Divaricatori Tebbets.....	78
Divaricatori Volkmann.....	73
Divaricatori Weitlaner.....	76
Divaricatori Wiener.....	86
Divaricatori Yancoskie.....	83
DURANTE pinze anatomiche.....	45
DUVAL pinza fenestrata.....	4

E

Elettrodi monopolari.....	158
Elevatore Langenbeck.....	101
Elevatore per periostio Masing.....	102
Elevatore per setto.....	104
Elevatore per setto Cottle.....	103-104

Elevatore per setto Cottle-Joseph.....	103
Elevatore per setto Freer.....	102
Elevatore per setto Hajek-Ballenger.....	104
Elevatore per setto Howarth.....	103
Elevatore per setto Joseph.....	102
Elevatore per setto Killian.....	103-104
Elevatore per setto McKenty.....	102-103
Elevatore per setto Pennington.....	103
Elevatore per setto Pierce.....	103
Elevatore per setto Sinus.....	103
Endo dissettore Langenbeck.....	77
Endo dissettore Langenbeck-Cottle.....	77
Endo dissettore Mini-Langenbeck.....	77

F

Face lift forbici Gorney.....	30
Face lift forbici Gorney-Freemann.....	30
Face lift forbici Kaye.....	31
Face lift forbici Peck-JOSEPH.....	31
FARABEUF divaricat.dopp.coppia.....	65
FERRIERA divaricatori.....	78
FERRIS SMITH pinze chirurgiche.....	42
FINSEN divaricatori.....	75
FOMON forbici nasali.....	27
FOMON Periostotomo.....	101
FOMON raspa nasale doppia.....	136-137
FOMON retrattori nasali.....	88
FOMON scalpelli nasale.....	127
Forbice delicata Bonn.....	20
Forbici blefaroplastica.....	32
Forbici bleforaplastica	
Greenberg-Par.....	32
Forbici delicate.....	20-25
Forbici delicate CONVERSE/WILMER/WALTER.....	22
Forbici delicate Cottle.....	22
Forbici delicate Gradle.....	23
Forbici delicate Graefe.....	22
Forbici delicate IRIS.....	20
Forbici delicate Knapp.....	21
Forbici delicate Littler.....	22
Forbici delicate Wagner.....	25
Forbici endoscopici.....	156
Forbici gengivali Chadwick.....	26
Forbici gengivali Goldmann-Fox.....	29
Forbici gengivali La Grange.....	26
Forbici gengivali Mc Indoe.....	29
Forbici nasali Caplan.....	122
Forbici nasali Cottle.....	27
Forbici nasali Cottle-Masing.....	27

Forbici nasali Fomon.....	27
Forbici nasali Gorney.....	122
Forbici nasali Heymann.....	27
Forbici per dissezione.....	13-19
Forbici per dissezione Joseph.....	18
Forbici per dissezione Kilner.....	19
Forbici per dissezione Lexer-Baby.....	15
Forbici per dissezione Mayo.....	13
Forbici per dissezione Mayo-Stille.....	14
Forbici per dissezione Metzenbaum.....	16-17
Forbici per dissezione Sanvenero.....	18
Forbici per strabismo.....	24
Forbici taglia fili Littauer.....	28
Forbici taglia fili O'Brien.....	28
Forbici taglia fili Spencer.....	28
FRAZIER uncinetto.....	70
FRAZIER/FERGUSSON cannula di aspirazione.....	108
FREEMAN divaricatori.....	68, 84
FREEMAN, strumento per marcare.....	4
FREER coltello per il setto nasale.....	124
FREER coltello per mucosa.....	124
FREER elevatore per setto.....	102
FREER retrattore nasale.....	88
FREER scalpelli per plastica nasale.....	128
FREER sgorbia nasale.....	132
FRIEDMAN micro pinza sgorbia.....	98
FRIEDMAN mini pinza sgorbia.....	98

G

Ganci per tracheotomia Jackson.....	90
Gancio per tracheotomia News.....	90
GERALD pinza chirurgica 1x2.....	43
GERALD pinze anatomiche.....	43
GERALD pinze chirurgiche.....	44
GERZOG Martello metallico.....	100
GILLIES Divaricatori.....	89
GILLIES pinze 1x2 denti.....	43
GILLIES portaghi tagliente.....	94
GLABELLA raspa nasale.....	134
GOLDMANN-FOX forbici gengivali.....	29
Goniometro Moeltgen.....	2
Goniometro per le dita.....	2
GORNEY dissettore.....	102
GORNEY divaricatore.....	84
GORNEY face lift forbici.....	30
GORNEY forbici nasali.....	122
GORNEY-FREEMAN face lift forbici.....	30
GRADLE forbici delicate.....	23

GRAEFE forbici delicate.....	22
GRAEFE pinza morsi dentellati.....	41
GRAEFE pinze per iride.....	52
GRAEFE uncinetto acuto.....	69
GRAEFE uncinetto smusso.....	69
GREEN pinze fissatrici.....	56
GREENBERG-PAR forbici bleforoplastica.....	32
GROSSMAN, strumento per marcare.....	4
GUILLEN cannula di aspirazione.....	109
GUTHRIE uncinetto doppio acuto.....	69
GUTHRIE uncinetto doppio smusso.....	69

H

HAJEK sgorbia.....	132
HAJEK-BALLENGER elevatore per setto.....	104
HALPREN strumento per marcare.....	5
HALSEY portaghi.....	91
HALSTED-Mosquito micro pinze.....	60
HALSTED-Mosquito pinze.....	60
HARTMANN pinza per polipi nasali.....	117
HARTMANN pinze emostatiche.....	59
HARTMANN specoli nasali.....	111
HARTMANN-HALLE specoli nasali.....	110
HEYMANN forbici nasali.....	27
HEYMANN KNIGHT pinza nasale.....	118
HOLZHEIMER divaricatori.....	75
HOWARTH elevatore per setto.....	103
HUMBY dermatomo.....	7
HUMBY uncinetto doppio per pelle.....	71

I

IRIS forbici delicate.....	20
----------------------------	----

J

JACKSON ganci per tracheotomia.....	90
JANSEN divaricatori.....	75
JANSEN-GRUENWALD pinza auricolare.....	57
JENNINGS apribocca.....	141
JOSEPH (LEWIS) raspa nasale.....	135
JOSEPH bisturi per cartilagine.....	124
JOSEPH bisturi per rinoplastica.....	124
JOSEPH elevatore per setto.....	102
JOSEPH forbici per dissezione.....	18
JOSEPH lima per ossa.....	134
JOSEPH Periostotomo.....	101
JOSEPH sega nasale.....	138

JOSEPH sega nasale angolata.....	139
JOSEPH uncino mucosa.....	70
JOST tritacartilagine.....	133

K

KASDAN divaricatore.....	73
KAYE face lift forbici.....	31
KAYE forbici blefaroplastica.....	32
KELLY forbici per dissezione.....	19
KELLY pinze emostatiche.....	51
KELLY RANKIN pinze emostatiche.....	61
KILLAN specoli nasali.....	113-114
KILLIAN CLAUS sgorbia.....	132
KILLIAN elevatore per setto.....	103-104
KILLIAN sgorbia.....	130
KILNER DOUGHTY abbassalingua.....	143
KILNER DOUGHTY apribocca.....	143
KILNER forbici per dissezione.....	19
KILNER retrattore nasale.....	88
Klapp divaricatori.....	72
KLEINERT-KUTZ uncinetto acuto per pelle.....	70
KNAPP divaricatore.....	86
KNAPP forbici delicate.....	21
KNIGHT pinza per il setto.....	118

L

La GRANGE forbici gengivali.....	26
LAHEY divaricatori.....	70
Lama di ricambio per dermatomo.....	6
Lama di ricambio, non sterile.....	7
Lame per bisturi.....	11
LANGE divaricatore.....	89
LANGENBECK elevatore.....	101
LANGENBECK Endo disettore.....	77
LANGENBECK-COTTLE Endo disettori.....	77
LERCHE pinza 5x6 denti.....	41
LERICHE pinze emostatiche.....	63
LEXER forbici per dissezione.....	15
LEXER-BABY forbici per dissezione.....	15
Lima per ossa Joseph.....	134
LITTAUER forbici taglia fili.....	28
LITTLER forbici delicate.....	22
LOCKWOOD, Separatori mammari.....	82
LOCKWOOD strumento per marcare.....	3
LUBET-BARBON pinza per medicature..	117

LUC pinza tagliante per il setto nasale....	119
LUCAE pinze auricolari.....	57

M

MacCollum-DINGMANN separatori mammari.....	81
MAINIAC retrattore nasale.....	87
MALTZ (COTTLE) raspa nasale.....	135
MALTZ raspa nasale.....	134
Manici per lame bisturi.....	8-12
Martelli.....	100
Martello intranasale Quisling.....	100
Martello Mead.....	100
Martello metallico Cottle.....	100
Martello metallico Gerzog.....	100
Martello metallico Partsch.....	100
MARTINEZ-KILNER divaricatore.....	89
MASING elevatore per periostio.....	102
MASING-NEIVERT retrattore nasale.....	87
MAYO forbici per dissezione.....	13
Mayo-HaberISSER pinze torcifili.....	97
MAYO-Hegar portaghi.....	92
MAYO-Stille forbici per dissezione.....	14
MC INDOE cesoia per ossa.....	99
MC Indoe forbici gengivali.....	29
McINDOE pinza 1x2 denti.....	42
MCINDOE pinza anatomica.....	42
McIVOR abbassalingua.....	144
McIVOR apribocca completo.....	144
McKENTY elevatore per setto.....	102-103
McKISSOCK, strumento per marcare.....	5
MEAD martello.....	100
METZENBAUM forbici per dissezione.....	16-17
MEYERDING divaricatori.....	74
Micro forbici.....	33-35
Micro pinze ad anello.....	48
Micro pinze Halsted-Mosquito.....	60
Micro pinze per legature.....	47
Micro portaghi Barraquer.....	95
Micro portaghi Castroviejo.....	96
MICROVASCULAR portaghi.....	93
MIDDLETON JANSEN pinza per il setto nasale.....	123
MILLARD uncini.....	84
MILLER divaricatore.....	86
MINI-LAMBOTTE osteotomo.....	132

MINI-LANGENBECK Endo dissetto	77
MOELTGEN goniometro	2
MYLES pinza nasale tagliente	121

N

NEIVERT-ANDERSON Osteotomo	130
NEWS gancio per tracheotomia	90

O

O'BRIEN forbici taglia fili	28
OBWEGESER divaricatore	146-148
OBWEGESER Osteotomo	131
OBWEGESER periostotomo	149
OCHSNER pinza per dissezione	45
O'CONNOR divaricatore	86
OLSEN HEGAR portaghi	93
Osteotomo Cinelli	127
Osteotomo Cottle	129
Osteotomo fomon	127
Osteotomo Mini-Lambotte	132
Osteotomo nasale Silver	130
Osteotomo nasale West	132
Osteotomo Neivert-Anderson	130
Osteotomo Obwegeser	131
Osteotomo Rubin	129
Osteotomo sheehan	127
Osteotomo Tessier	151
Ottica per endoplastica	152

P

PARKES raspa nasale	134
PARTSCH martello metallico	100
PECK-JOSEPH face lift forbici	31
PEET raspa nasale	134
PENNINGTON Elevatore per setto	103
Periostotomo doppio Dingman	150
Periostotomo Fomon	101
Periostotomo Joseph	101
Periostotomo Obwegeser	149
PIERCE Elevatore per setto	103
Pinza 1 x 2 denti Potts-Smith	36
Pinza 1x2 denti McIndoe	42
Pinza 5x6 denti Lerche	41
Pinza a baionetta Taylor	44
Pinza anatomica McIndoe	42
Pinza anatomica Bonney	45
Pinza anatomica Cushing	41
Pinza anatomica Potts-Smith	36
Pinza auricolare Jansen-Gruenwald	57
Pinza auricolare Wilde (Troeltsch)	57

Pinza chirurgica 1x2 Gerald	43
Pinza chirurgica Cushing	41
Pinza chirurgica Stille	37
Pinza con cucchiaio, modello russo	42
Pinza depilatoria Barraquer	55
Pinza emostatica ADSON	64
Pinza fenestrata Collin-Duval	42
Pinza fenestrata Duval	42
Pinza morsi dentellati Graefe	41
Pinza nasale Heymann-Knight	118
Pinza nasale tagliente Myles	121
Pinza nasale tagliente Schmeden	121
Pinza nasale tagliente Takahashi	121
Pinza p. diss. 1x2 denti	37
Pinza p. dissezione micro	43
Pinza per appiattimento setto nasale Rubin	122
Pinza per columella Cottle	57
Pinza per dissezione Ochsner	45
Pinza per il setto Knight	118
Pinza per il setto nasale Brünings	119
Pinza per il setto nasale Craig	119
Pinza per il setto nasale Middleton Jansen	123
Pinza per medicature Lubet-Baron	117
Pinza per medicature Westmacott	117
Pinza per polipi nasali HARTMANN	117
Pinza per raddrizzare il setto nasale Asch	140
Pinza per raddrizzare il setto nasale Walsham	140
Pinza sgorbia Beyer	98
Pinza sgorbia BOEHLER	98
Pinza sgorbia Friedmann	98
Pinza sgorbia mini Friedman	98
Pinza tagliente nasale Weil-Blakesley	120
Pinza tagliente per il setto nasale Luc	119
Pinza torcifili Berry	97
Pinza USA 1x2 denti	37
Pinza USA p. dissezione	36
Pinze 1x2 denti Gillies	43
Pinze 1x2 denti Semken	43
Pinze ADSON, chirurgiche	39
Pinze ADSON, chirurgiche/ anatomiche	38
Pinze ADSON-BROWN, chirurgiche	40
Pinze anatomiche Durante	45
Pinze anatomiche Gerald	43

Pinze anatomiche Semken	43
Pinze anatomiche Stille	36
Pinze atraumatiche DeBakey	50-51
Pinze auricolari Lucae	57
Pinze auricolari Troeltsch	57
Pinze chirurgiche 2x3 denti	37
Pinze chirurgiche 3x4 denti	37
Pinze chirurgiche 4x5 denti	37
Pinze chirurgiche Brown	41
Pinze chirurgiche Ferris-Smith	42
Pinze chirurgiche Gerald	44
Pinze chirurgiche Stille-Barraya	45
Pinze chirurgiche Waugh	41
Pinze da presa per endoscopia	157
Pinze emostatiche Coller-Crile	61
Pinze emostatiche Crile	62
Pinze emostatiche Crile-Rankin	62
Pinze emostatiche Hartmann	59
Pinze emostatiche Kelly	61
Pinze emostatiche Kelly-Rankin	61
Pinze emostatiche Leriche	63
Pinze emostatiche Providence-Hospital	61
Pinze emostatiche Rochester-Ochsner	63
Pinze emostatiche Rochester-Pean	63
Pinze fissatrici Green	56
Pinze Halsted-Mosquito	60
Pinze muscolari BERKE	55
Pinze per calazio Desmarres	55
Pinze per dissezione chirurgiche	37
Pinze per dissezione, chirurgiche/anatomiche	36
Pinze per iride Bishop-Harman	53
Pinze per iride Graefe	52
Pinze per schegge	46
Pinze per sutura Castroviejo	55
Pinze per sutura mod. Bonn	54
Pinze per sutura mod. Tuebingen	54
Pinze per tessuti Singley	45
Pinze torcifili Mayo-Haberisser	97
PITANGUY strumento per marcare	3
Placca per palpebre	58
Placca per stendipelle	6
Portaghi Baby Olsen-Hegar	93
Portaghi Baby-Webster	91
Portaghi Baumgartner	92
Portaghi Crile-Wood	92
Portaghi DeBakey	92
Portaghi Derf	91
Portaghi Halsey	91

Portaghi Mayo-Hegar	92
Portaghi microvascolari	93
Portaghi Olsen-Hegar	93
Portaghi Ryder.....	93
Portaghi tagliente Gillies.....	94
Portaghi Webster.....	91
POTTS SMITH pinze anatomiche	36
POTTS-SMITH pinza 1 x 2 denti.....	36
Providence-Hospital pinze emostatiche	61

Q

QUISLING martello intranasale	100
-------------------------------------	-----

R

RAGNEL divaricatore doppio	65
RAMUS divaricatore	148
Raspa nasal Dingman	138
Raspa nasale Aufricht.....	135
Raspa nasale doppia Fomon.....	136-137
Raspa nasale Glabella	134
Raspa nasale Joseph Lewis.....	135
Raspa nasale Maltz	134
Raspa nasale Maltz (Cottle)	135
Raspa nasale Parkes	134
Raspa nasale Peet.....	134
Raspa nasale Wiener	134
REDA coltello falcato	125
Regolo metal.grad.mm/pollici	2
Retratore nasale Freer	88
Retratore nasale Kilner.....	88
Retratore nasale Maliniac.....	87
Retratore nasale Masing-Neivert.....	87
Retrattori nasali Aufricht	87
Retrattori nasali Converse	87
Retrattori nasali Cottle	87-88
Retrattori nasali Fomon	88
Retratore nasale Cottle-Neivert.....	88
REYNOLDS forbici per dissezione	19
REYNOLDS (Transauxillary)	
Separatori mammari	81-82
RIBBON spatole addominali.....	66
ROCHESTER OCHSNER pinze emostatiche	63
ROCHESTER PEAN pinze emostatiche	63
ROLLET divaricatore	86
ROUX mini divaricat.doppio	65
RUBIN osteotomo	129
RUBIN pinza per appiattamento setto nasale	122

RUSSEL-DAVIS abbassalingua	145
RYDER portaghi	93

S

SANVENERO forbici per dissezione ..	18
Scalpello per plastica nasale Cottle...	129
Scalpelli per plastica nasale Freer.....	128
SCHINK Dermatomo	6
SCHMEDEN pinza nasale tagliente	121
SCULPO divaricatori con camicia per chirurgia plastica.....	79
Sega nasale angolata Joseph	139
Sega nasale Joseph.....	138
SEMKEN pinze 1x2 denti	43
SEMKEN pinze anatomiche	43
Separatori mammari Agris-Dingman ..	81
Separatori mammari MacCollum-Dingmann	81
Separatori mammari LOCKWOOD.....	82
Separatori mammari REYNOLDS (Transauxillary).....	81
Separatori mammari Silverstein	82
Separatori mammari Tebbetts	81
Sgorbia Freer.....	132
Sgorbia Hajek	132
Sgorbia Killian.....	130
Sgorbia Killian-Claus	132
Sgorbia nasale West	132
Sgorbia periostotomo Boies	102
SHEEHAN scalpelli nasale.....	127
SILVER dermatomo.....	7
SILVER osteotomo nasale	130
SILVERSTEIN separatori mammari ..	82
SINGLEY pinze per tessuti.....	45
SINUS elevatore per setto.....	103
Spatola	80
Spatole addominali Ribbon.....	66
Spazzolino	138
Specoli nasali	112
Specoli nasali Cottle	115-116
Specoli nasali Hartmann.....	111
Specoli nasali Hartmann-Halle	110
Specoli nasali Killian.....	113-114
Specoli nasali Tieck-Halle.....	112
Specoli nasali, mod. Wien	112
SPENCER forbici taglia fili.....	28
SPINA-NASALIS divaricatore.....	148
STEVENS forbici delicate.....	24
STILLE pinza chirurgica.....	37
STILLE pinze anatomiche	36

STILLE-BARRAYA pinze chirurgiche	45
STRANDELL-STILLE divaricatori.....	74
Strumenti per labbra e palato	105
Strumenti per labbra e palato Blair....	106
Strumento per marcare D'Assumpcao	3
Strumento per marcare Lockwood	3
Strumento per marcare Pitanguy.....	3
Strumento per marcare, Ackermann.....	5
Strumento per marcare, FREEMAN.....	4
Strumento per marcare, GROSSMAN....	4
Strumento per marcare, Halpren.....	5
Strumento per marcare, McKissock	5

T

TAKAHASHI pinza nasale tagliente...121	
TAYLOR pinza a baionetta	44
TAYLOR pinza anatomica	44
TAYLOR pinza chirurgica 1x2.....	44
TEBBETTS divaricatori.....	78
TEBBETTS Separatori mammari	81
Telaio solo per Davis Boyle	142
Telaio solo per Davis-Meyer	144
Telaio solo per Dingmann.....	143
Telaio solo per Kilner-Doughty.....	143
TESSIER divaricatore	150
TESSIER Osteotomo.....	151
TIECK HALLE specoli nasali	112
Tritacartilagine Cottle.....	133
Tritacartilagine Jost	133
TROELTSCH pinze auricolari.....	57
TYRELL uncinetto acuto.....	69

U

Uncinetto acuto Frazier	70
Uncinetto acuto Graefe.....	69
Uncinetto acuto per pelle Kleinert-Kutz.....	70
Uncinetto acuto Tyrell	69
Uncinetto doppio acuto Guthrie	69
Uncinetto doppio per pelle Humby	71
Uncinetto doppio smusso Guthrie	69
Uncinetto per pelle Barsky.....	71
Uncinetto smusso Frazier.....	70
Uncinetto smusso Graefe	69
Uncini Millard	84
Uncini per dura-madre Adson.....	85
Uncini per nervi Crile	85
Uncini per nervi Cushing	85
Uncini per nervi destra e sinistra	77

Uncini per pelle Anderson.....	84
Uncino mucosa Joseph	70

V

VOLKMANN divaricatori.....	73
----------------------------	----

W

WAGNER forbici delicate	25
WALSHAM pinza per raddrizzare il setto nasale	140
WALTER/CONVERSE/WILMER forbici delicate.....	22
WATSON dermatomo	7
WAUGH pinze chirurgiche.....	41
WEBSTER portaghi.....	91
WEIL BLAKESLEY pinza tagliente nasale	120
WEITLANER divaricatori	76
WEST osteotomo nasale	132
WEST sgorbia nasale	132
WESTMACOTT pinza per medicature	117
WIEDER abbassalingua	141
WIENER divaricatori.....	86
WIENER raspa nasale.....	134
WILDE (TROELTSCH) pinza auricolare.....	57
WILLIGER dissettori.....	101

Y

YANCOSKIE divaricatori	83
------------------------------	----

Hauptkatalog Chirurgische Instrumente
General catalog surgical instruments

HNO
ENT

Arthroskopie
Arthroscopy

Container Steriltechnik
Container Sterilization Technique

Endoskopie
Endoscopy

HERCULES® Drahtkneifzange
HERCULES® Wire Cutters

Neurochirurgie
Neuro Surgery

Orthopädie
Orthopedic

Titan Instrumente
Titanium Instruments

+Redamed

Maltepe Mah.
Eski Çırpıcıyolu Sk.
Merter İş Merkezi D Blok
2/21 034234
Zeytinburnu, İstanbul

+90 212 482 71 52
info@redamed.com

